



## CURRICULUM AUTHORIZATION STATEMENT

In accordance with Federal civil rights law and U.S. Department of Agriculture (USDA) civil rights regulations and policies, the USDA, its Agencies, offices, and employees, and institutions participating in or administering USDA programs are prohibited from discriminating based on race, color, national origin, sex, religious creed, disability, age, political beliefs, or reprisal or retaliation for prior civil rights activity in any program or activity conducted or funded by USDA.

Copyright © 2019 National 4-H Shooting Sports Program

All rights reserved. No part of the publication may be reproduced or transmitted in any form or by any means, electronic or mechanical, including photocopy, recording, or any information and retrieval system, without written permission from the National 4-H Shooting Sports Program. Under no circumstances may any material be reproduced for resale. This curriculum is provided solely to certified 4-H Shooting Sports instructors who have successfully completed a 4-H Shooting Sports training recognized by the state where they are enrolled as a certified volunteer. Persons possessing this curriculum without appropriate training are not authorized to conduct a shooting sports training for 4-H or other organizations nor are they authorized to lead any 4-H Shooting Sports projects.

Please send requests in writing to:

Program Coordinator  
National 4-H Shooting Sports Program  
[coordinator@4-hshootingsports.org](mailto:coordinator@4-hshootingsports.org)

## INDEX – MUZZLELOADER

|  |                                  |         |
|--|----------------------------------|---------|
| First Shot Fundamentals .....  | Page 4                           |         |
| Targeting Life Skills.....   | Page 6                           |         |
| Lesson 1 – Outline: Muzzleloading Safety .....                         | Page 7                           |         |
| Lesson 1 – Narrative: Muzzleloading Safety .....                       | Page 15                          |         |
| Lesson 2 – Outline: Shooting and Cleaning Muzzleloading Rifles.....    | Page 21                          |         |
| Lesson 2 – Narrative: Shooting and Cleaning Muzzleloading Rifles ..... | Page 27                          |         |
| Lesson 3 – Outline: Muzzleloading and Muzzleloading Equipment .....    | Page 32                          |         |
| Lesson 3 – Narrative: Muzzleloading & Muzzleloading Equipment .....    | Page 38                          |         |
| Lesson 4 – Outline: Shooting Muzzleloading Shotguns (Optional).....    | Page 45                          |         |
| Lesson 4 – Narrative: Shooting Muzzleloading Shotguns (Optional).....  | Page 52                          |         |
| Lesson 5 – Outline: Shooting Muzzleloading Handguns (Optional).....    | Page 57                          |         |
| Lesson 5 – Narrative: Shooting Muzzleloading Handguns (Optional) ..... | Page 62                          |         |
| Lesson 5 – Cap and Ball Revolvers (Optional) .....                     | Page 66                          |         |
| FACT SHEETS  |                                  |         |
| Determining Eye Dominance .....  | Fact Sheet 3 .....               | Page 70 |
| Non-threatening Hands-on Instruction .....                             | Fact Sheet 4 .....               | Page 75 |
| Trajectory & Trajectory Experiments.....                               | Fact Sheet 5 .....               | Page 76 |
| Pistol & Rifle Range Commands.....                                     | Fact Sheet 16 .....              | Page 81 |
| Rifle & Pistol Shooting Procedures .....                               | Fact Sheet 17 .....              | Page 83 |
| Analyzing Groups for Form Faults in Pistol Shooting.....               | Fact Sheet 18 .....              | Page 85 |
| Trigger Squeeze.....   | Fact Sheet 19 .....              | Page 87 |
| Penetration & Shock Demonstration.....                                 | Fact Sheet 20 .....              | Page 88 |
| Simple Muzzleloading Rifle or Shotgun Loading Stand.....               | Fact Sheet 21 .....              | Page 89 |
| Muzzleloading Ammunition .....   | Supplemental Sheet 1 .....       | Page 91 |
| Loading a Muzzleloader .....   | Supplemental Sheet 2 .....       | Page 92 |
| Triggers.....  | Muzzleloading Fact Sheet 34..... | Page 94 |
| Barrel & Rifling .....   | Muzzleloading Fact Sheet 35..... | Page 95 |

|  |                                   |          |
|--|-----------------------------------|----------|
| CO2 Discharger .....                             | Muzzleloading Fact Sheet 36 ..... | Page 96  |
| In-Line Muzzleloader.....                        | Muzzleloading Fact Sheet 37 ..... | Page 97  |
| Types of Black Powder .....                      | Muzzleloading Fact Sheet 38 ..... | Page 98  |
| Loading Table Diagram .....                      | Muzzleloading Fact Sheet 39 ..... | Page 99  |
| Load Every Charge With Care .....                | Muzzleloading Fact Sheet 40 ..... | Page 100 |
| Live Fire Practical Range Responsibilities ..... | Muzzleloading Fact Sheet 41 ..... | Page 101 |
| Range Layout Briefing .....                      | Muzzleloading Fact Sheet 42 ..... | Page 102 |
| Range Layout Loading .....                       | Muzzleloading Fact Sheet 43 ..... | Page 103 |
| Shotgun Chokes & Patterns For Lead Shot .....    | Muzzleloading Fact Sheet 44 ..... | Page 104 |
| Range Layout Firing Exercise.....                | Muzzleloading Fact Sheet 45 ..... | Page 105 |
| Parts of a Muzzleloader .....                    | Muzzleloading Fact Sheet 46.....  | Page 107 |
| Accuracy & Anatomical Knowledge Required .....   | Muzzleloading Fact Sheet 47.....  | Page 108 |
| Alternate Muzzleloading Procedure.....           |                                   | Page 109 |
| Muzzleloading Misfire Procedure.....             |                                   | Page 110 |
| Pulling a Ball Procedure.....                    |                                   | Page 110 |
| Proposed Level 1 Training Outline.....           |                                   | Page 111 |

# First Shot Fundamentals Muzzleloader

Prior to class

Set up range with a 50 caliber caplock muzzleloader and all equipment for students to fire two shots each.

Welcome

Restrooms

Class Procedure

Pledge allegiance to the United States Flag

4-H Pledge

Lesson Time

One hour

Objectives of the lesson

1. Basic parts of a muzzleloading rifle
2. Explain and demonstrate how to check if a muzzleloading rifle is unloaded and safe
3. Dominate eye role
4. Understand basic range rules and etiquette for muzzleloaders

Safety

1. Eye Protection
2. Ear Protection

Parts of a Muzzleloader

Rules of firearm safety

1. Always keep the muzzle of the gun pointed in a safe direction
2. Always keep the muzzleloader uncapped or primed until ready to shoot
3. Always keep your finger off the trigger until ready to shoot

Sight alignment

Rear sight

Front sight

Sight Picture

Rear sight

Front Sight

Target

Dominate eye

Range rules / Range Commands/ Cease Fire

Go to range

Explain and demonstrate special safety procedures for muzzleloaders

Explain Hangfires and Missfires

Demonstrate how to load and fire a muzzleloader

Work with each student to allow them to load and fire two shoots on a plain target back

Summarize what you have covered

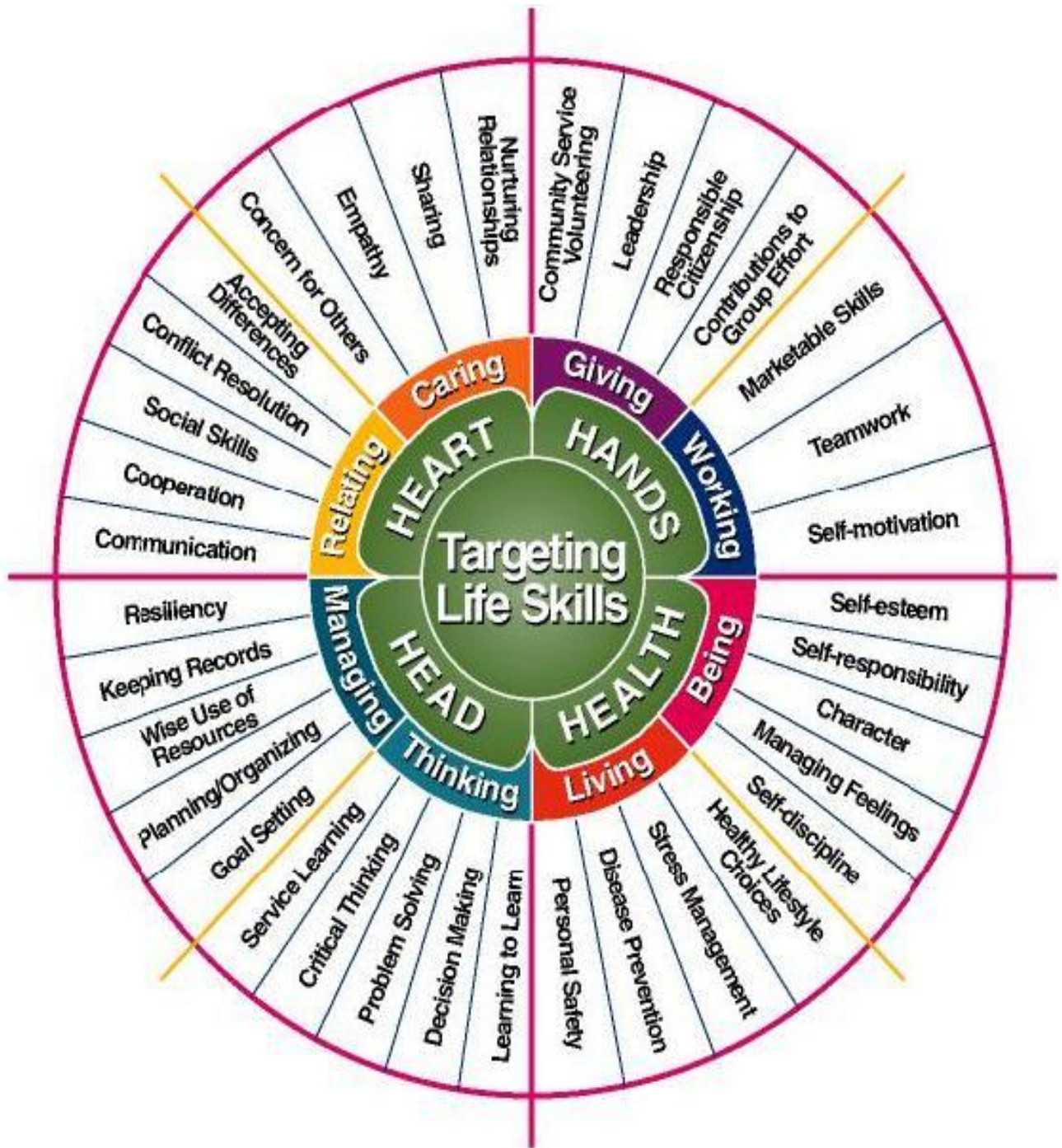

Iowa State 4-H Youth Development – Targeting life Skills Model  
 Reprinted by Permission Iowa State University.

# Muzzleloading Safety

## Objectives

---

Participating youth and adults will:

1. Understand the basics of black powder and muzzleloading safety.
2. Demonstrate safe loading procedures.
3. Demonstrate understanding of safe storage for powder and percussion caps.
4. Demonstrate proper handling of muzzleloaders on the range and in the field
5. Demonstrate use of proper eye and ear protection.
6. Have fun while learning.

## Roles for Teen and Junior Leaders

- Demonstrate loading and firing procedures
- Assist shooter with loading.
- Serve as a range assistant at one shooting station.
- Watch a single firing point as a safety officer.
- Assist with cleaning guns after the activity.
- Demonstrate proper field handling of muzzleloaders.

## Parental Involvement

- See Roles for Teen and Junior Leader above.
- Arrange for or provide shooting equipment and materials.
- Arrange for or provide classroom and range space.
- Serve as range officer or assistants.
- Arrange for or provide transportation.
- Arrange for or provide refreshments.

\* Executive with Thomson/Center Arms and a member of the National 4-H Shooting Sports Committee; and 4-H and Youth Development Specialist.

## Best Time to Teach

Any time of year but before shooting muzzleloading rifles, pistols or shotguns

## Best Location

Classroom and range

## Time Required

About 1 hour

## Materials/Equipment

- eye and ear protection
- muzzleloading rifles (percussion and flintlock)
- black powder and black powder substitutes in appropriate granulations
- powder flask or horn (1 per station)
- powder measure (1 per station)
- patches or patching materials
- patch lubricant
- round balls (appropriate diameter)
- ball starter and ball puller
- CO<sub>2</sub> discharger
- percussion caps
- priming flask (1 per flintlock)
- spare flints and spare nipple
- nipple wrench and nipple pick
- sighting-in targets
- black powder solvent
- worm (1 per station)
- range rod
- wiping rag or towel (1 per station)
- Murphy's oil soap and alcohol
- screwdriver
- wedge pin puller
- cleaning brush
- gun oil

## References

*National Muzzleloading Rifle*

*Association Instructor Workbook.*

Friendship, IN.

*The Muzzleloading Rifle Handbook* J.W.

Carlson and S. Davenport, eds.

National Rifle Association and

National Muzzleloading Rifle

Association, Washington, DC and

Friendship, IN 1985.

*State and provincial hunter education*

*manuals .Black Powder, White Smoke..*

Video. Contact your state 4-H Shooting

sports coordinator or hunter education

coordinator.

*Manufacturer's catalogs and*

*instructional handbooks.*

# Teaching Outline

---

## Presentation

### I. Black powder and muzzleloading arms

- A. Black powder and Black Powder Substitutes
  - 1. Only safe propellants for muzzleloaders
  - 2. Explosive burning rates
- B. Muzzleloading arms
  - 1. Rifles, pistols, shotguns, and muskets
  - 2. Common parts
    - Lock
    - Stock
    - Barrel
  - 3. Ignition
    - matchlock
    - wheel lock
    - flintlock
  - 4. Muzzleloading accessories

### II. Muzzleloading arms

- A. Rifles, pistols, shotguns and muskets
- B. Common parts
  - 1. lock
  - 2. stock
  - 3. barrel
- C. Ignition systems
  - 1. matchlock
  - 2. wheel lock
  - 3. percussion or caplock
- D. Muzzleloading accessories

### III. Muzzleloading safety

- A. All firearms safety rules apply to muzzleloaders too
  - 1. Self-control
    - personal responsibility for use of firearm
    - only real safety is person behind the gun
  - 2. Muzzle control
    - under control at all times
    - point in safe direction
      - down range
      - straight up
      - away from people
      - only at things you intend to shoot
        - absolute target identification
        - safe zone of fire

## Application

Conduct a brief REVIEW of materials covered in the previous lesson.

Briefly REVIEW parts of muzzleloading arms and the types of ignition systems commonly used.

DISCUSS fundamental rules of safe firearms handling. EMPHASIZE personal responsibility

- mousetrap pistol
- passing firearm with ramrod in barrel
- say “Thank you” – take responsibility
- say “You’re welcome” – give up responsibility

DEMONSTRATE muzzle control using adult assistants or teen leaders and empty firearms.

Have shooters DEFINE “safe direction” and “safe zone of fire” in the context of the range or classroom setting.

3. Trigger Control
  - A. Finger off trigger until ready to fire
    - last check point under mental control
4. Load (cap or prime) only when ready to fire
  - treat with respect due a loaded gun
  - assume loaded until personally verified as empty
  - measuring with ramrod
    - check length of barrel inside and outside
    - use marked ramrod
      - empty mark
      - marked for specific load
- B. Personal protective gear
  1. Eye protection essential
  2. Ear protection essential
- C. Further safety considerations
  1. Proper storage and handling of powder and percussion caps
  2. Loading from the muzzle
    - minimize exposure of hands, face and body
      - keep muzzle pointed away from body
      - handle ramrod with minimum exposure necessary
      - NEVER blow down barrel
    - minimize amount of exposed powder
      - NEVER load from stock container
      - always use a powder measure not attached to powder flask

DEMONSTRATE proper trigger control and finger position. STRESS control BEFORE the shot.

HOLD UP an empty firearm. ASK if the firearm is dangerous. STRESS the safety of empty firearms and the need for personal verification EVERYTIME.

DEMONSTRATE ways of determining if a muzzleloader is empty.

DISCUSS importance of eye and ear protection and DEMONSTRATE proper use.

DISCUSS and DEMONSTRATE proper storage and loading procedures.

ASK why special care is necessary when loading a muzzleloader.

DEMONSTRATE ways to minimize exposing body to risk while loading.

ASK why loading directly from a container is extremely dangerous.

STRESS the need to use a separate powder measure and to keep the amount of powder exposed to a minimum.

- seal powder container before pouring powder in barrel
- minimize sources of sparks
  - NO smoking
  - NO firing over powder container
  - use non-sparking tools
    - brass
    - copper
    - horn
    - wood
  - swab barrel with moist patch between shots
- 3. Seat projectile fully on powder
  - potential barrel obstruction
    - barrel damage
    - danger to shooter and bystanders
  - clean frequently
    - eases loading
    - reduces potential for stock load
  - mark ramrod
    - empty mark
    - marked for your load
  - seat firmly but do not pound on projectile
- D. Muzzleloader safeties
  1. No safety device completely secure
    - aid to safe handling
    - half cock safety can fail under some conditions
  2. Empty muzzleloader
    - “dump it in the hill”
      - fire into backstop
      - not aimed at target
      - use silent discharge
    - deactivate powder and pull charge
      - remove nipple
      - remove barrel from stock
      - soak breech end in water at least one hour
      - pull ball
      - wash powder from bore

DEMONSTRATE danger from sparks with a SMALL amount (a few grains) of powder

ASK why swabbing the bore between shots is a good safety practice. DISCUSS the answers, emphasizing loading ease and eliminating sparks.

EMPHASIZE using a marked ramrod to prevent barrel obstructions.

DISCUSS and DEMONSTRATE firmly seating a bullet on the powder.

ASK if mechanical devices ever break or fail.

DISCUSS the mechanical nature of safety devices and the need to use them only as a supplement to safe firearms handling.

ASK how a muzzleloader can be made safe. OUTLINE ways to remove a load from a muzzleloader.

3. Temporary caplock safety
  - remove the percussion cap
    - caution needed
    - avoid sharp or sparking objects
  - cover nipple with leather scrap
  - gently lower hammer onto padded nipple
  - **do NOT DRY FIRE**
4. Flintlock safety
  - lift frizzen and remove
  - cover frizzen with leather “glove”
  - insert pipe cleaner in flash hole
  - lower cock gently to fired position

DISCUSS removing the cap and covering the nipple for temporary safety. DEMONSTRATE the process and POINT OUT the precautions.

DISCUSS and DEMONSTRATE deactivating a flintlock temporarily by removing the powder, covering the frizzen and sealing the flash hole.

### III. Handling black powder safely

#### A. Proper storage

1. Use original containers
  - avoids confusion
  - designed for safe storage
  - never glass
2. Cool, dry place
  - heat sensitive
  - hygroscopic
    - draws water from air
    - deactivated by water
  - free from oil and solvents
3. Away from flame or sparks
  - explosive
  - away from primers, caps and other powders

ASK shooters to outline proper storage of powder to protect both people and the powder.

EMPHASIZE these points and add any not presented.

#### B. Use secure carrying devices

1. Carry only the amount needed
  - horn or flask
  - pre-measured pellets
2. Sealed, waterproof containers
3. Non-sparking materials
4. Never Glass

DEMONSTRATE proper ways of carrying powder in the field or on the range.

DEMONSTRATE the use of one or more measures

#### *Fact Sheet #11*

#### C. Load from a separate measure

1. NEVER from main container
2. Proper amount and granulation
  - follow manufacturer’s recommendations
  - double check safety
3. Develop safe loading system

DISCUSS the need to stay within the manufacturer’s recommendations.

EMPHASIZE the need for attention and concentration.

- D. Caution and care required
  1. Muzzle in safe direction
  2. No distractions

#### IV. Developing a safe loading procedure

- A. Attitude
  1. Alert
  2. Attentive
  3. Important Action
- B. Check condition of arm
  1. Start with a clean barrel
  2. Make sure it is empty by checking with ramrod
- C. Swab bore with alcohol moistened patch or solvent soaked patch
  1. Removes oil, fouling or moisture
  2. Snuffs out lingering sparks
  3. Eases bullet seating
- D. Clear flash hole or nipple
  1. Caplock
    - fire one or more caps
    - muzzle in safe direction
    - watch for gas movement by holding muzzle near leaf, grass or similar object
    - clear nipple with pick
  2. Flintlock
    - wipe pan, frizzen and flint with alcohol
    - dry each surface
    - clear flash hole with pick
- E. Carefully measure powder
  1. Within manufacturer's limits
  2. Powder measure separate
  3. Seal horn or flask before charging gun
- F. Pour powder charge in barrel
  1. Tap side of barrel to settle charge
  2. Keep face and hands clear of muzzle
  3. Avoid double charging or failure to charge with powder
- G. Center lubed patch on muzzle
  1. Cotton or linen
    - proper thickness
    - proper size
    - no synthetics
    - possible bore fouling
    - potential obstructions
    - no sabots for same reasons

DEMONSTRATE and DISCUSS a safe loading procedure starting with a clean, empty muzzle loader and with one that has just been fired.

EMPHASIZE the need to start with a clean bore

DEMONSTRATE pre-loading preparation with both caplock and flintlock arms.

Refer to *Fact Sheet #12: Loading Table Firearm Bench*.

Fire two caps before loading. 1<sup>st</sup> cap down range, 2<sup>nd</sup> at grass and watch for movement.

EMPHASIZE the need for paying attention to the loading sequence and being sure to load exactly as recommended.

*Fact Sheet #13*

Recommended powder charge for beginning shooters is 30 gr

DISCUSS need for a tight fit and reasons for using natural fibers and avoiding synthetics.

2. Lubricants
  - saliva or “spit patch”
  - bullet lube
  - vegetable shortening
  - patch lube
  - saliva available, but poorest performance

SHOW potential patch lubricants and DISCUSS their relative merits.

H. Start ball into bore

1. Center ball in muzzle
  - sprue up
  - centered in patch
2. Start with short starter
  - sharp blow or push with hand
  - trim excess patching material
3. Push ball deeper with long starter

DEMONSTRATE use of a short starter

DEMONSTRATE use of a long starter

I. Seat ball on powder

1. Minimize hand exposure
2. Grip ramrod just above muzzle
  - 15 to 20 cm (6 to 8 inches) above the muzzle
  - avoids breaking ramrod and damage to hand
3. Seat ball firmly on powder
  - leave no air space
  - check against marks on ramrod

DEMONSTRATE proper use of the ramrod and CAUTION shooters about proper hand position on the rod.

REINFORCE use of a marked ramrod for safety.

J. Replace ramrod in thimbles

K. Now move from the loading area to the firing line

L. Prime pan or cap nipple

1. flintlock
  - prime pan with FFFFg
  - do not cover flash hole
2. Percussion – seat cap on nipple

Have demonstrator FIRE the muzzleloader and repeat the loading process with a fired gun.  
(See new CD from CMP Fundamentals)

**V. Shooting fundamentals**

**VI. Firing the first shot with a Muzzleloader**

- A. Standard range procedures
  1. One range assistant for each shooting station
  2. Wide spacing of shooters
  3. Use loading stands or tables
- B. Load and fire on commands
  1. Check your rifles
  2. Swab bore with alcohol patch
  3. Clear nipple or flash hole
  4. Measure and load powder

Use standard range procedures. See *Fact Sheet #16: Rifle and Pistol Range Commands and Procedures*.  
Range Practical

SPACE shooters at least 2 meters or 10 feet apart and have a range assistant at each firing point to assist shooters.

LOAD muzzleloaders on command using mild powder charges

- pre-set powder measures
  - use light load
  - close can or horn before dropping powder
  - strike side of barrel with hand
5. Center lubricated patch on muzzle
  6. Center ball on patch with sprue up
  7. Start ball with short starter
  8. Push ball deeper with long starter
  9. Seat ball on powder
    - use ramrod properly
    - check seating depth with marked ramrod
  10. Cap or prime
  11. Are when ready
  12. Swab bore with solvent soaked patch

## VI. Summary

- A. Storage of powder
- B. Loading
  1. Handling powder
  2. Developing a safe loading process
  3. Importance of loading care
  4. Checking the finished product
- A. Firing a shot
- B. Rifle shooting and cleaning next time

Consider using .32 or .36 caliber rifles (90% of all muzzleloaders & accessories available are .50 cal.).

.50 caliber – easily obtained/use 50 grain charge  
light recoil  
carbine length

ASSIST shooters as needed

WATCH use of the ramrod and CORRECT hand position immediately.

KEEP muzzles down range

CLEAN bore with solvent patch before placing rifle in rack.

REVIEW major elements of lesson using questions to stimulate thinking.

PREPARE shooters for live firing in the next session.

# Lesson Narrative 1

---

## Black Powder and Muzzleloading Arms

Muzzleloading firearms safely use only black powder or Black powder substitutes. Both propellants burn very quickly at explosive rates. As a result, they demand special care on the part of the shooter.

Muzzleloading firearms are available in rifles, pistols, shotguns and muskets. All of them share some common parts: lock, stock and barrel. In the last session we looked at muzzleloaders and their history. The predominant types available today are flintlock and percussion or caplock arms. Matchlock and wheel lock guns are primarily of historical interest.

## Basic Firearms Safety and Muzzleloaders

All the basic firearms safety rules apply to handling muzzleloading arms. The shooter must exercise personal responsibility for use of any firearm, since the only real safety device on firearms is the user.

### **The first cardinal rule on firearms safety requires that the shooter have self-control**

The first cardinal rule on firearms safety requires that the shooter have self-control. Another cardinal rule is to control the muzzle at all times. The shooter is responsible for keeping the muzzle pointed in a safe direction. That direction is governed by common sense and the conditions at the time. In most instances the muzzle may be safely pointed down range or straight up. It must never be pointed toward another person. The muzzle never should be pointed at anything you do not intend to shoot. In a field situation that demands absolute and complete target identification. In all cases it demands that a safe zone of fire be clearly identified. It also demands that the shooter know where the projectile will stop, that an adequate backstop be identified and that entire field of fire to backstop be clear and safe.

The last checkpoint for a shooter before the projectile is fired is the trigger. The finger should stay off the trigger until the shooter is in the act of firing a shot. Keeping the finger along the side of the trigger guard helps to prevent accidental discharges.

The firearm should not be loaded until it is ready to be fired. In muzzleloading arms, the shooter may wait until just before the shot to cap or prime the gun. A gun with a cap on its nipple or a closed flash pan should be considered loaded and ready to fire. Every muzzleloader should be treated with the respect due a loaded firearm until it is personally determined empty. The condition of the muzzleloader can be checked by using a ramrod after the ignition system is rendered safe by removing the cap or lifting the frizzen and removing all priming powder. Insert the ramrod into the bore, marking the point where it emerges from the muzzle. Then hold the ramrod beside the barrel with the mark even with muzzle. If the end of the ramrod reaches the nipple or the flash hole, the barrel is empty. If it does not, the gun should be considered loaded. Many shooters mark the ramrod twice - once for an empty gun and a second time for a specific, preferred load.

**The first cardinal rule on firearms safety requires that the shooter have self-control.**

**Another cardinal rule is to control the muzzle at all times.**

**The firearm should not be loaded until it is ready to be fired. In muzzle-loading arms, the shooter may wait until just before the shot to cap or prime the gun.**

Eye protection is essential to all persons on the firing line with muzzleloaders.

Loading should NEVER take place from a stock container.

Smoking should never be permitted around gun powder, especially with black powder. Powder containers should be located so shooters will not be firing over them. A spark from a muzzle is just as dangerous. Shooters should also be careful to use only non-sparking tools and equipment around black powder.

A shooter should NEVER attempt to clear any obstruction, including a lodged ball, by firing.

Personal protective gear is vitally important to muzzleloader shooters. Muzzleloading arms vent a portion of their gases through the nipple or flash hole. In addition, chips of flint, steel filings or bits of the percussion cap may be ejected during firing. The eyes are exposed to all these potential dangers. Eye protection is essential to all persons on the firing line with muzzleloaders. In addition, flintlock shooters should be given a wide safety zone on the lock side to avoid the gases and smoke from the flash hole. Ear protection is as important to muzzleloader shooters as it is to shooters using fixed ammunition.

## **More Safety Considerations for Muzzleloaders**

Several additional safety concerns are associated with loading a muzzleloader. Powder and percussion caps must be properly stored and handled carefully. Since the shooter is loading from the muzzle, care is essential. The shooter should minimize the exposure of their hands, face and body during the loading process. The muzzle must be pointed away from the body. The ramrod must be handled with the minimum exposure of the hands necessary. Finally, the shooter should NEVER blow down the barrel to make sure the barrel is clear. This is extremely hazardous and places a vital part of the body directly over the muzzle. NEVER point a gun at something you do not intend to shoot.

Since black powder burns explosively, the amount of powder exposed should be minimized. A powder measure separate from the flask or horn should be used to transfer powder from the stock container to the firearm. Loading should NEVER take place from a stock container. It is equivalent to holding a bomb. To reduce the potential for an accident, seal or cover the stock container before pouring the powder into the barrel.

Sources of sparks should also be minimized. Smoking should never be permitted around gunpowder, especially with black powder. Powder containers should be located so shooters will not be firing over them. A spark from a muzzle is just as dangerous. Shooters should also be careful to use only non-sparking tools and equipment around black powder. Tools may be made of brass, copper, horn, wood or similar materials. Finally, the shooter should make sure there are no lingering sparks in the barrel from the previous shot. Swabbing the barrel between shots with a moistened patch reduces fouling, eases loading and snuffs out any sparks that remain.

The projectile must be firmly seated on the powder. If not, it forms a barrel obstruction and poses a danger to the shooter and bystanders. Seating problems may be avoided by frequent cleanings. A clean barrel loads more easily than a fouled one and reduces the potential for a stuck load. A shooter should NEVER attempt to clear any obstruction, including a lodged ball, by firing. Either seat the bullet completely or remove the stuck projectile properly. Marking the ramrod provides a ready check on seating. Bullets should be seated firmly, but they should not be pounded into place.

## **Safeties and Making Muzzleloaders Safe**

Muzzleloaders do not have safeties in the same sense as breech-loading arms. Most muzzleloading arms have a half-cock feature that holds the hammer or cock off the nipple or frizzen. Most muzzleloaders can have the hammer fall front that position under severe enough circumstances, like dropping the firearm from a tree. The device is merely an aid to otherwise sound firearms handling.

Unlike breech-loading firearms, muzzleloaders cannot be easily opened and cleared. The easiest and preferred way of emptying a muzzleloader is to fire it in a safe place. In competitive events, the range officer will give the command to "dump it in the hill." Shooters fire their loads into the backstop without aiming at targets.

If shooting is not possible or the arm will not fire, a more involved process is necessary. Using a CO<sub>2</sub> discharger is a preferred and safer method. If a CO<sub>2</sub> discharger is not an option then the powder charge must be deactivated, and the bullet must be pulled. To deactivate the powder charge, remove the nipple from the breech and remove the barrel from the stock. Soak the breech end of the barrel in a bucket of water for at least one hour. Using a work rod and a ball, screw the ball puller into the ball or bullet and pull the ball. Then thoroughly scrub the bore to remove all powder residues, just as you would when cleaning the muzzleloader.

Field shooters may need to make their muzzleloaders safe temporarily in many types of situations. In percussion guns that can be accomplished by removing the percussion cap from the nipple carefully. Avoid using sharp objects or those that might strike sparks. Once the cap has been removed, place a small scrap of leather over the nipple and gently lower the hammer onto the leather. Do not dry fire a percussion gun! The impact of the hammer on the nipple will damage the nipple severely.

Flintlocks can also be made safe temporarily. Lift the frizzen, exposing the priming powder in the flash pan. Remove all the powder carefully by blowing or wiping it away. Cover the frizzen with a leather sleeve or glove to protect the steel surface. Insert a pipe cleaner into the flash hole and lower the cock to the fired position with the frizzen still raised. Remember, an unprimed or uncapped muzzleloader is still loaded and could fire under the right conditions! Keep them pointed in a safe direction.

## **Handling Black Powder Safely**

Black powder must be stored properly for safety purposes. Use the original containers for storage. That avoids all confusion because the powder is stored in labeled and properly identified containers. It increases safety because the containers are designed for storing powder. Glass or plastic should not be used. Glass may break, the solvents in the plastic may react with the powder and both materials may build up static electricity.

Powder should be stored in a cool, dry place. It is heat sensitive and hygroscopic, meaning that it draws moisture from the air. Wet powder can become deactivated, causing all sorts of difficulties for the shooter. The storage area should also be free of solvents and oil, which can react with the powder and deactivate it.

The storage area should be free from flame and sparks. It should not contain percussion caps, primers or other types of powder. It should not have motors present, since they produce sparks during operation.

Since black powder is hygroscopic and explosive, only the amount needed for a day afield or on the range should be carried at any given time

Since black powder is hygroscopic and explosive, only the amount needed for a day afield or on the range should be carried at any given time. It can be carried safely in sealed, waterproof containers made of non-sparking materials. Powder horns are traditional devices for carrying powder, but powder pouches of leather or flasks made of brass or copper also are in common use. Some shooters prefer to carry pre-measured powder charges in small vials or specimen tubes.

Powder should always be measured carefully. Shooters may use a hollow piece of antler or horn, an empty cartridge case or an adjustable measure to dispense powder. Measures attached to powder containers should not be used. Powder should never be poured directly from the container into the barrel. The shooter should work up appropriate loads, following the manufacturer's recommendations. Be sure to use the proper granulation. Each step should be double-checked to be sure proper procedures have been followed. Shooters should develop a safe, habitual loading routine with complete attention to detail, caution and care. The muzzle should be pointed in a safe direction throughout the loading process.

## Developing a Safe Loading Procedure

**One of the keys to safe loading is the attitude of the shooter.** Loading the muzzleloader should be taken seriously because mistakes can be dangerous or even fatal. The shooter must be alert and attentive, giving the procedure undivided attention.

**See page 109 for alternate muzzleloading procedure.**

**The first step in loading a muzzleloader is to verify its condition,** making sure it is empty. The hammer should be raised to the half-cock position with the flash pan empty or the nipple without a cap. Then the barrel should be checked with the ramrod to see if it is empty. The shooter may measure the ramrod against the barrel or use a mark ramrod. The barrel should be clean, and new barrels should be carefully cleaned before they are fired for the first time.

**The next step is to swab the barrel with a patch** moistened with alcohol or black powder solvent. This patch eliminates oil, moisture and powder residues. It also snuffs out any lingering sparks from a previous shot. This swabbing process also eases the passage of the next ball or bullet by cleaning the bore.

Wise shooters now clear the nipple or flash hole by firing once down range. Caplock firearms may be cleared by firing several caps. The muzzle must be pointed in a safe direction, away from people and powder. It should be held close to a light object, such as a leaf or blade of grass, to detect the passage of gas from the barrel. Movement of the object indicates that the barrel is clear, and the nipple is clear. If debris from the caps fills the nipple, it must be removed with a nipple pick. Flintlock shooters must clean the frizzen, pan and flint with alcohol and dry thoroughly. The flash hole can be cleared with a pipe cleaner or pick.

Next, the powder charge is measured carefully. The horn or flask is sealed before the powder is poured into the muzzle. Keeping the face, hands and body clear of the muzzle the shooter dumps the powder into the muzzle. Striking the side of the barrel with the flat of the hand settles the powder. The shooter must be careful not to double charge or excessively charge the gun with powder, making sure the charge is within the manufacturer's recommended listings.

If a patched ball is being used, the shooter centers a cotton or linen patch of the proper size and thickness over the muzzle. The patch forms the seal between the bore and the ball, so it must match the bore and the ball diameter closely. Avoid synthetic patches or plastic sabots. The rifle manufacturer's warranty may be voided because these materials can leave fouling that is very difficult to remove.

The patch should be lubricated. Several types of lubricants may be used effectively. Bullet lube, special patch lubes, vegetable shortening or even saliva can be used to lubricate the patch. The "spit patch" is handy all the time, but it often gives more erratic performance. In hunting situations, the spit patch can dry out, losing its lubricating and sealing capacity.

The next step is to start the ball into the bore. The ball is centered in the bore with the sprue (the flat part where the mold cuts the lead off) facing up. The short starter is then used to push the bullet into the muzzle slightly. At that point, excess patching material may be cut off with a patch knife. Then the ball is pushed a short distance down the bore with the long starter. Finally, it is seated completely on the powder with the ramrod.

The ramrod should be grasped only about 15 to 20 centimeters (6 to 8 inches) above the bore. That prevents breaking the ramrod and risking injury from broken parts of the ramrod. Push the ball down the bore with a series of short strokes, seating it firmly on the powder. Do not pound on the ball. That deforms it and risks poor down-range performance. Check the bullet seating depth with the marked ramrod and be sure to leave no air spaces! Any gap makes the bullet behave as a bore obstruction with potentially hazardous results.

Bullets do not require a patch. The lubricated bullet is pressed into the muzzle and pushed down onto the powder with the ramrod. The same precautions apply to bullets and patched balls.

Once the bullet or ball is seated, replace the ramrod in thimbles. In a flintlock, prime the pan with a small amount of FFFFg powder. (Fill pan about  $\frac{1}{3}$  full). More is not better, and the flash hole should not be covered with powder. Covering the flash hole slows ignition and makes it less dependable. Close the frizzen, and the flinter is ready to cock and fire. Percussion firearms need a cap seated on the nipple to prepare them for firing.

## **Firing the First Shot**

Now let's move the first relay of shooters to the firing line. We will load the muzzleloaders and fire one shot on command. If you need help, the range assistant at your station will help you with loading. Check to make sure your rifle is safe. Now swab the bore with a patch soaked in alcohol. Clear the nipple by firing several caps or clear the flash hole and clean the frizzen and flint with alcohol. Carefully measure a powder charge and close the container. Dump the powder down the barrel, keeping the muzzle clear of your face, hands and body. Strike the side of the breech a couple of times to settle the powder. Place a lubricated patch over the muzzle (keeping it away from your body and slightly down range). Center a ball in the muzzle with the sprue pointing upward. Use the short stem on the starter to start the bullet into the bore. Press it further down the bore with the longer extension on the starter. Properly using the ramrod, push the ball down onto the powder firmly. Check the seating depth with the marks on the ramrod. Now move from the loading area to the firing line. Cap the nipple or prime the pan and fire when command is given. When command is given, then move ahead of loading bench to the firing line.

## **Summary**

In this session we concentrated on using black powder and muzzleloading arms safely. We considered safe procedures of handling and storing black powder. We discussed the fundamentals of safe muzzleloading and safe firearms handling and noted the special considerations needed when a firearm is loaded from the muzzle. We developed a procedure for safely loading a muzzle loader and stressed that muzzleloading takes complete concentration. Finally, we loaded and fired a muzzleloader. Next time we will do more live firing with a rifle and learn how to clean muzzleloading firearms.

## **Summary Activities**

1. Have shooters outline proper storage procedure for black powder.
2. Have shooters outline and discuss shooting safety with specific reference to muzzleloaders.
3. Have shooters develop a safe loading routine and discuss the reasons for using each step.
4. After having every shooter fire the muzzleloaders, ask them to describe the process and discuss their feelings about them.

## **Exhibit and Sharing Ideas**

1. Develop a checklist or poster series on safe handling and storage of percussion caps and black powder.
2. Demonstrate proper handling of muzzleloading firearms and discuss the importance of each element in the process.
3. Demonstrate proper loading sequence for muzzle loading rifles.
4. Share what you have learned with an interested adult.
5. Write what you learned in your shooting journal. Exhibit the journal in an appropriate event or activity.
6. Experiment with different loads in a muzzleloader. Report your findings in an appropriate setting.

# Shooting and Cleaning Muzzleloading Rifles

---

## Objectives

Participating youth and adults will:

1. Practice loading and firing muzzleloading rifles.
2. Develop skills in cleaning muzzleloading rifles.
3. Be able to strip and reassemble a muzzleloader.
4. Practice basic firearms and range safety.
5. Have fun while learning.

## Roles for Teen and Junior Leaders

- Demonstrate range or shooting procedures
- Assist with range management.
- Assist at one shooting station.
- Serve as assistant range officers.
- Conduct a fun shoot with muzzleloaders.
- Demonstrate and assist with gun-cleaning exercise.
- Lead discussions on use of muzzleloaders and selection of proper rifles for those uses.

## Parental Involvement

- See Roles for Teen and Junior Leaders above.
- Arrange for or provide shooting and cleaning equipment.
- Arrange for or provide range or cleaning space.
- Arrange for or provide transportation.
- Arrange for or provide refreshments.
- Develop and manage a fun shoot for muzzleloaders.

\* Executive with Thomson/Center Arms and a member of the National 4-H Shooting Sports Committee, and 4-H and Youth Development Specialist.

## Best Time to Teach

Any time outdoor range use is possible (repeat as needed)

## Best Location

Range and cleaning area with water available

## Time Required

About 1 hour

## Materials/Equipment

- eye and ear protection
- rifles
- loading stand or bench
- powder and powder measures
- patches and patch lubricant
- balls
- ball starters
- percussion caps or priming powder
- nipple wrench and nipple pick
- worm and ball puller
- CO<sub>2</sub> discharger
- cleaning jag
- work or range rod
- Murphy's oil soap and alcohol
- cleaning patches
- black powder solvent
- gun oil cleaning cloth
- brushes
- tools to disassemble firearms.

## References

*National Muzzleloading Rifle*

*Association Instructor Workbook.*

National Muzzleloading Rifle Association, Friendship, IN.

*The Muzzleloading Rifle Handbook.* J.W.

Carlson and S. Davenport, eds.

National Rifle Association and

National Muzzleloading Rifle

Association, Washington, DC and

Friendship, IN. 1985. Manufacturer's catalogs and instructional handbooks.

State or provincial hunter education manuals.

*Black Powder, White Smoke.* Video.

Contact your state 4-H shooting sports coordinator or hunter education coordinator.

## Teaching Outline

---

### Presentation

#### I. Muzzleloading safety

- A. Black powder
  - 1. Proper storage
  - 2. Careful handling
- B. Basic firearms safety
  - 1. Cardinal rules
    - self-control
    - muzzle control
    - trigger control
    - loaded (capped or primed)
  - 2. Additional rules
    - target identification
    - down-range safety
    - adequate backstop
    - personal responsibility
- C. Muzzleloader safety
  - 1. Is it loaded?
    - checking personally
    - cap or priming powder
    - barrel length
    - marked ramrod
  - 2. Loading from the muzzle
    - minimal exposure of body, head and hands
    - minimal exposed powder
    - safe loading procedure
    - safe loads
- D. Firing a muzzleloader

#### II. Shooting muzzleloading rifles

- A. Standard range management
  - 1. Adequate space between stations
  - 2. One range assistant per station
  - 3. Loading tables or shooting stands
- B. Standard shooting procedure
  - 1. Loading procedure
  - 2. Range commands
  - 3. Coach-pupil shooting
  - 4. Shooting positions

### Application

REVIEW basic firearms and muzzleloading safety by asking shooters to OUTLINE the fundamentals.

STRESS these cardinal rules of firearms safety.

Have shooters DEMONSTRATE these processes.

REFER to *Fact Sheet #16: Rifle and Pistol Range Commands and Procedures* for details if needed.

*Fact Sheet #14 (1-5) Range Practicum*

See *Fact Sheet #13: A Simple Muzzleloading Rifle or Shotgun Loading Stand*.

### **See page 109 for Alternate Muzzleloading Procedure**

See rifle lesson plans for shooting form and sequence if positions will be taught in this discipline

Coach-pupil system is a must

DISCUSS these factors and their importance.

- C. Rifle shooting considerations
1. Clean bore
  2. Proper powder and charge
  3. Proper wad and ball combination
    - cotton or linen
    - proper thickness
    - proper size
    - lubricant
  4. Adequate for use
- D. Coping with misfires and hang-fires
1. Definitions
    - misfire – failure of the main charge to fire
    - hang-fire – delayed ignition of the main charge
  2. Possible causes
    - obstruction of nipple or flash hole
    - improper loading
    - priming powder covering flash hole
    - wet powder
    - oil in flash hole or nipple
    - wet percussion cap
    - wet or oily frizzen or flint
    - soft frizzen – inadequate spark
    - dull or poorly adjusted flint
  3. Safety considerations
    - *always* control the muzzle
    - hold down range for *two* minutes
      - expect delayed firing
      - listen for evidence of possible ignition
      - use extreme caution
    - keep muzzle in a safe direction
    - make firearm “safe”
      - remove cap or priming powder
      - cover nipple or frizzen

PREPARED to DISCUSS matching the arm to the use.

DEFINE misfire and hang-fire, noting that they are more common with muzzleloaders than with cartridge firearms.

DISCUSS possible causes of these problems. ASK shooters to DISCUSS any reasons for failure to fire.

**See page 110 for misfire and ball pulling procedures**

STRESS the importance of *keeping the firearm pointed in a safe direction for at least two minutes*. Be prepared for the rifle to fire

STRESS the necessity to make the firearm as safe as possible before proceeding.

DEMONSTRATE each of these actions as they are discussed.

4. Procedures for percussion arms
  - inspect cap and nipple
  - clear any obstruction from nipple
  - seat new cap fully
  - attempt to fire again
    - remove nipple
    - remove barrel
    - soak breech in water for one hour
    - pull ball and clean bore
    - dry barrel, reassemble rifle and start again
      - unloaded firearm
    - pull ball
    - load properly
    - fire

NOTE that the load or bullet may move from the pressure of the cap.

NOTE that a CO<sub>2</sub> discharger is a safer method

5. Procedures for flintlocks
  - inspect and clean flint and frizzen
  - clean and dry flash pan
  - clean and clear flash hole
  - prime and attempt to fire
  - continued failure to fire
    - work small amount of dry powder through flash hole – prime
    - attempt to fire
    - continued failure to fire
    - loaded
      - deactivate powder as above
      - pull ball and charge
      - dry and assemble gun
      - check for adequate spark
      - load and fire – no powder loaded

STRESS the importance of a clean, dry flint and frizzen.

STRESS using only a small amount of priming powder and keeping the flash hole clear.

- pull ball
- load properly
- fire

### III. Cleaning muzzleloaders

- A. Importance of proper cleaning
  - 1. Clearing barrel of obstructions
    - oil preservatives
    - powder fouling
  - 2. Corrosive residues
    - sulfur and nitrogen compounds
    - draw water to form acids
    - bore damage happens quickly
  - 3. Barrel or lock damage
    - structural damage
    - cosmetic damage
    - potential danger
- B. Benefits of proper cleaning
  - 1. Longer life of firearm
  - 2. Usefulness and accuracy
    - preserving barrel condition
    - functional utility
  - 3. Safety
    - loading ease
    - structural strength
- C. Cleaning procedure
  - 1. Remove barrel from stock
    - remove barrel wedge
    - unhook barrel from tang
  - 2. Remove nipple or flash hole insert
  - 3. Clean barrel
    - immerse breech in cleaning solution
    - pump solution through bore
      - swab bore with patched jag
      - swab until clear
    - scrub threads with brush
    - rinse with cleaning solution
    - dry bore
      - several dry patches
      - oil very lightly
    - oil barrel surface lightly
    - dry and replace nipple or flash hole insert

DISCUSS the reasons for prompt and thorough cleaning of muzzleloading firearms.

DEMONSTRATE proper cleaning techniques on one firearm. Have teams of shooters CLEAN the rifles they used

STRESS the need for a proper jag and patch combination to get a good fit on the bore

USE gun oil or a moisture protectant

4. Remove lock
    - scrub with soapy water
    - rinse with hot water
    - dry thoroughly
    - oil lightly
  5. Clean stock
    - wipe away surface fouling
    - treat any stock scratches
      - boiled linseed oil
      - commercial stock finish
    - avoid soaking with gun oil
  6. Replace barrel and lock
- D. Secure storage
1. Dry area
  2. Controlled access
  3. Muzzle down
    - allows excess oil to drain
    - prevents ignition problems
    - prevents stock damage

STRESS proper stock care and avoiding excessive gun oil on wood surfaces.

DISCUSS proper storage of muzzleloaders to prevent damage and keep them secure

#### IV. Summary

- A. Review of safety
  1. Powder
  2. Basic firearms safety
  3. Muzzleloading safety
    - loading
    - shooting
    - misfire and hang-fire procedures
- B. Basic rifle shooting procedure
  1. Range commands
  2. Shooting procedures
  3. Shooting positions
  4. Matching arms to uses
- C. Cleaning procedures
  1. Bore and barrel
  2. Lock
  3. Stock
- D. Storage

Use QUESTIONS to stimulate a summary discussion of basic points covered in the lesson.

REPEAT the lesson as necessary or adopt the basic rifle shooting process with muzzleloaders if desired.

## Lesson Narrative 2

---

### Muzzleloading Safety

Black powder is a low-yield explosive. It must be stored and handled carefully to avoid hazards to the shooter and bystanders. Like other types of firearms, muzzleloaders must be handled in accordance with the cardinal rules of firearms safety: shooters must exercise self-control and personal responsibility at all times. They must keep the muzzle pointed in a safe direction. Their fingers must stay off the trigger until ready to shoot, and they must load, cap or prime only when about to shoot.

Muzzleloading firearms share with other types of firearms the need for clear target identification, an adequate backstop, clear zones of fire and other features of down-range safety. The unique character of muzzleloading arms adds some additional safety considerations. Like other arms, they must be checked to verify their condition. Unlike breech-loading arms, muzzleloaders must be checked from the muzzle. They must have the cap or priming powder removed before checking them. The bore can be checked with a marked ramrod or by comparing the length of the ramrod inside the bore with its position outside the barrel.

Loading and firing requires a safe procedure with safe loads. Powder container must be closed after filling powder measure during loading. The possibility of an injury to the shooter exists should an accidental discharge occur.

### Shooting Muzzleloading Rifles

Shooting procedures and range management for muzzleloading rifles differ in a few ways from cartridge arms. The shooting stations are farther apart, particularly when flintlocks are being used. Some of the gases vented during firing are ejected to the lock side of the firearm, posing a potential hazard to other shooters. Adequate space between shooting stations avoids problems from those gases or foreign materials carried by them.

Muzzleloaders also require more space for loading. A loading stand or table promotes safety, helping the shooter keep the muzzle pointed in a safe direction. If a loading area behind the firing line is used, the assistant at each firing point must reinforce proper muzzle control during the entire loading and firing process.

We will be using the same range management and shooting procedures used in pistol and rifle shooting with a couple of significant additions. [See *Fact Sheet 17: Pistol and Rifle Shooting Procedures* for more detail and include that orientation in this section.] The "load" command will be expanded when shooting by commands. Shooters will "swab the bore" with alcohol on that command, then clear *the* nipple or flash hole. The next command will be to "measure

**Some of the gases vented during firing are ejected to the lock side of the firearm posing a potential hazard to other shooters. Adequate space between shooting stations avoids problems from those gases or foreign materials carried by them.**

your powder charge." On that command shooters will measure the powder charge, seal the stock container and pour the powder into the barrel. "Seat a ball on the powder" directs the shooter to start a patched ball, seat it on the powder charge, check for proper seating depth and replace the ramrod in the thimbles.

A loading bench behind the firing line is mandatory. The shooter will then be instructed to "move to the firing line." They should hold the muzzle straight up while turning and stepping to the firing line. The command to "prime" or "cap your rifle" is the last loading step. It should be completed after the rifle has been pointed down range. The other major change from the standard range commands is that "make your rifle safe" may be preceded by "dump it in the hill," meaning that the shooter should fire any charge left in the rifle into the backstop but not at the target.

**See page 109 for alternate muzzleloading procedures**

Once shooters have demonstrated their ability to follow proper loading and range procedures, a coach-pupil teaching technique will be used. A range assistant should be on the firing line at each station throughout the firing session to be sure that the shooters are following proper procedures.

*Instructor's note:* Instruction in position shooting, if it is conducted here, should follow the same format as the instruction in the rifle section of this manual.

## **Handling Misfires and Hang-fires**

Muzzleloader shooters encounter ignition problems more frequently than shooters using cartridge arms. The way these situations are handled determines whether they are an inconvenience or a potential hazard. Misfires occur when the main charge fails to fire. They may or may not involve detonation of the cap or a "flash in the pan."

Extreme caution is essential when the rifle does not fire immediately.

Regardless of whether or not the cap detonated, or the priming powder flashed, the firearm should remain pointed down range for at least two minutes. During the wait, the shooter should be prepared for the arm to fire at any time.

**See page 110 for Misfire and Proper Unloading Procedures**

A hang-fire is a delayed ignition of the main charge. Sometimes hang-fires can be heard sizzling or hissing before the main charge fire. Sometimes they give no evidence of their presence until the firearm goes off. Extreme caution is essential when the rifle does not fire immediately.

Many causes of hang-fires or misfires can be identified. The nipple or flash hole may be obstructed. Even covering the flash hole with priming powder invites a slow ignition or hang-fire. The firearm may have been loaded improperly, for example loading without a powder charge. The powder, either the main charge or the priming powder, may have gotten wet, deactivating it. Water or oil may be filling the flash hole of nipple. The percussion cap may have gotten wet or oily, preventing it from detonating. The frizzen may be oily, wet or worn so the metal dents without producing a shower of sparks. Poor sparks can also be the result of a flint that is dirty, wet, oily or dull.

Several safety precautions must be taken with all misfire or hang-fire situations. Regardless of whether or not the cap detonated or the priming powder flashed, the firearm should remain pointed down

range for at least two minutes. During the wait, the shooter should be prepared for the arm to fire at any time. The muzzle must *always* be pointed in a safe direction and the firearm must be made safe by removing the cap or clearing the flash pan and padding the nipple or covering the frizzen. Even after these precautions, avoid unnecessary exposure to the muzzle. Follow a multi-step process with either a percussion arm or a flintlock. First return to the loading bench keeping the muzzle pointed in a safe direction. Lay the rifle on the bench with the muzzle ahead of the forward edge of the loading bench pointed down range.

**The muzzle must *always* be pointed in safe direction and the firearm must be made safe by removing the cap or clearing the flash pan and padding the nipple or covering the frizzen.**

With percussion guns, the first step is to inspect the cap and the nipple. Check the cap to be sure it had a priming compound inside and that it was struck by the hammer. Check the nipple to see if any part of the priming compound or other materials were obstructing the channel into the breech. If the cap fired, check the seating of the ball before proceeding. If the rifle is loaded, reseal the ball. Sometimes the pressure from the cap will move the ball slightly. Once that has been done, place a fresh cap on the nipple and attempt to fire once more. Use a CO<sup>2</sup> discharger if the muzzleloader still fails to fire repeat the sequence. Then try working a small amount of dry powder into the nipple with a pick or remove the nipple, pick out a small amount of powder place a tiny amount of fresh powder in the breech and replace the nipple. Complete the safety check then attempt to fire once more. Proceed if one is not available. DEACTIVATE the charge before going any further.

**Complete the safety check. Then attempt to fire once more. If the rifle fails to fire, DEACTIVATE the charge before going any further.**

Deactivate the powder by removing the nipple, removing the barrel from the stock and soaking the breech end of the barrel in water for at least an hour. After the powder has been thoroughly soaked. Use a ball puller to extract the ball and wash all powder from the barrel. After the barrel has been cleaned and dried, the rifle may be reloaded carefully and fired.

Flintlock arms have several other potential causes for misfires. The flint and frizzen should be examined, cleaned and dried. The flash pan and flash hole also must be clean and dry. Prime the arm with fresh powder and attempt to fire it once more.

If it still fails to fire, repeat those steps, then work a small amount of fresh powder through the flash hole with a pick and attempt to fire once more. If a loaded firearm still fails to fire, deactivate the powder, pull the ball and clean the rifle. When the rifle is assembled again, fire with an empty rifle to see if an adequate spark is produced. If not, sharpen or adjust the flint. Once the rifle is sparking properly, load and fire.

**Dischargers are not always available. Get samples from each manufacturer.**

## **Cleaning Muzzleloading Firearms**

It is important to keep all firearms clean. With muzzleloading arms, the need is even greater. Cleaning clears the barrel of fouling, oils or preservatives. It eliminates potential obstructions to loading or firing safely. Cleaning also eliminates the corrosive residues from burned black powder. Black powder contains both sulfur and nitrogen compounds. The sulfur gives black powder

smoke its distinctive odor. These compounds draw moisture from the air to form acids that can corrode or pit a rifle barrel in a short time. Some damage is only cosmetic. Serious damage can be unseen, and it affects accuracy and safety of the firearm. Severely damaged arms are unsafe to shoot. Proper cleaning prolongs the life of the firearm. It helps preserve the accuracy and usefulness of the arm by keeping the bore in top condition and by maintaining the structural strength of the barrel and its attachments.

Muzzleloaders are partially disassembled for cleaning. Remove the barrel from the stock by pulling the barrel wedge and unhooking the barrel from the tang. Remove the nipple or the flash hole insert with a wedge pin tool, screwdriver or another appropriate tool. Immerse the breech end of the barrel in a bucket of soapy water (dish detergent also may be used). Place a cleaning patch on the cleaning jag attached to a work rod or the ramrod and swab the bore thoroughly. Pump the soapy solution through the bore until the water comes out clean. Scrub the nipple and the flash hole insert with a small brush to remove all fouling from the channels and the threads. Rinse thoroughly in clean, hot water and set aside to dry. Rinse the barrel, flushing the inside thoroughly with hot water. Run several dry patches through the barrel to dry the bore. If any fouling is evident, repeat the barrel cleaning process until the patches are clean. After the barrel is dry, swab it with a lightly oiled patch to prevent corrosion. Wipe the surface with a moisture protestant. Replace the nipple or flash role insert.

Remove the lock from the stock. Clean the lock thoroughly by scrubbing it with soapy water, rinsing it in hot, clean water and drying it completely. Lightly oil the moving parts and the surface of the metal to prevent corrosion. Avoid oiling the face of the frizzen or getting oil on the flint or the leather padding for the flint. Too much oil is worse than not enough, so use the gun oil sparingly. Clean any powder residues from the stock with a soft brush and cloth. Use water or oil on the stock only if a severe problem exists. Scratches may be treated with boiled linseed oil (thinned with turpentine or mineral spirits) or with a commercial stock finish. Do not soak the stock with gun oil. It tends to destroy the wood. After all these things are done, attach the lock and barrel to the stock.

Store the firearm in a secure, dry area with a stable temperature. Controlled access is essential to prevent unauthorized use. Storing the muzzleloader with the muzzle down allows any excess oil to drain out of the barrel. That can help prevent ignition problems and stock damage caused by oil seepage.

## **Summary**

We reviewed the basics of black powder and muzzleloading safety. Muzzleloading shooting differs little from other forms of rifle shooting in range commands, procedures, safety precautions and shooting positions. We fired muzzleloaders and learned how to handle hang-fires and misfires. Finally, we learned proper cleaning and storage procedures for muzzleloading rifles. Next time we will explore the basics of shooting muzzleloading shotguns.

## **Summary Activities**

1. Have every pair of shooters clean the rifle they used.
2. Have shooters practice acting as range officers and assistants without equipment.
3. Use the sequence of teaching steps found in the basic rifle shooting lessons to teach a series of lessons on position shooting with muzzleloaders.
4. Have a fun shoot with clay targets, balloons or similar objects.

## **Exhibit and Sharing Ideas**

1. Record what you learned today in your shooting journal and exhibit that journal in an appropriate event or activity.
2. Study the history of the muzzleloading rifle or a particular type of muzzleloading rifle and report on it to your group or another interested person.
3. Experiment with different loads in your rifle. Try to find the most accurate load. Record your results and exhibit them in tabular form.
4. Demonstrate proper cleaning procedures for a muzzleloading rifle to an appropriate audience.
5. Outline muzzle loading range safety in a series of signs or posters and display them in an appropriate area at your host club or range.
6. Participate in a muzzle loading hunt or re-enactment of your choice. Record the event in your journal and exhibit it at an appropriate event or give an illustrated talk about it.

# Muzzleloading and Muzzleloading Equipment

---

## Objectives

Participating youth and adults will:

1. Understand the basics of muzzleloading history.
2. Develop familiarity with muzzleloading arms.
3. Understand the use of black powder and Black powder substitutes.
4. Understand the use of muzzleloading accessories.
5. Have fun while learning.

## Roles for Teen and Junior Leaders

- Demonstrate the various items of muzzleloading equipment.
- Demonstrate the difference between black and smokeless powders.
- Demonstrate assembly and disassembly of muzzleloader.
- Demonstrate use of eye and ear protection.
- Supervise participants exploring the assembled equipment.

## Parental Involvement

- See Roles for Teen and Junior Leaders above.
- Relate muzzleloading experiences.
- Arrange for or provide meeting place.
- Arrange for or provide equipment.
- Arrange for or provide transportation
- Arrange for or provide refreshments.

\* Executive with Thomson/Center Arms and a member of the National 4-H Shooting Sports Committee; 4-H and Youth Development Specialists.

## Best Time to Teach

Any time of year, but as first lesson

## Best Location

Indoor or outdoor classroom

## Time Required

About 1 hour

## Materials/Equipment

- muzzleloading rifles (sidehammer and flintlock)
- muzzleloading inline rifle
- muzzleloading shotgun or smoothbore rifle
- muzzleloading pistol
- round balls in various calibers
- minnie balls and maxi balls
- bullet lubricant
- patching material and patch lubricant
- percussion caps and flints
- cleaning jag and worm
- ball puller and ball starter
- CO2 discharger
- Capper
- powder cans (empty FFg, FFFg, FFFFg, Pyrodex)
- powder flask and powder horn
- powder measure and priming flask
- possibles bag and patch knife
- nipple wrench and nipple pick
- pipe cleaners
- black powder solvent and gun 011
- range rod
- Murphy's oil soap and alcohol
- ceramic or metal container
- eye and ear protection

## References

*The Muzzleloading Rifle Handbook.* J.W. Carlson and Davenport, eds. National Rifle Association of America and National Muzzleloading Rifle Association, Washington, DC. And Friendship, IN. 1985.

*The Muzzleloading Shotgun Handbook.* J.W. Carlson and S. Davenport, eds. National Rifle Association of American and National Muzzleloading Rifle Association, Washington, DC. And Friendship, IN. 1985.

*The Muzzleloading Pistol Handbook.* J.W. Carlson and S. Davenport, eds. National Rifle Association of America and National Muzzleloading Rifle Association, Washington, DC. And Friendship, IN. 1985.

## Teaching Outline

### Presentation

#### I. Muzzleloader origins and history

- A. Black powder
  1. First use – Chinese fireworks
  2. European adaptation
    - book on composition published – England, 1242 AD
    - use as explosive and possible firearm – Germany, early 1300's
- B. Muzzleloading arms
  1. Cannon in use - 1346 AD
  2. Hand cannon
  3. Matchlock
    - hot wire
    - slow match
  4. Wheel lock
    - first practical sporting
    - expensive and complex
  5. Flintlock
    - dominant for hundreds of years
    - simple and reliable
  6. Caplock
    - percussion cap
    - less open system
    - faster ignition
    - less weather sensitive
  7. Inline
    - percussion cap
    - closed system
    - fast ignition
    - not weather sensitive

#### II. Black powder and substitutes

- A. Only safe propellants for muzzleloaders
  1. NEVER smokeless powder
  2. Low yield explosives
  3. Relatively low pressures
    - powerful
    - function safely in open systems
- B. Black powder
  1. Composition, not color
    - Sulfur
    - Charcoal
    - Saltpeter (potassium nitrate)
    - Same basic formula since discovery

### Application

Briefly REVIEW the history of black powder and muzzleloading firearms.

ILLUSTRATE your points with posters, photographs or other materials to reinforce significant points in the discussion. Fact Sheets.

Film, "Black Powder, White Smoke".

NOTE that the blunderbuss often associated with the Pilgrims was a matchlock arm.

ILLUSTRATE wheel lock operation with a lighter.

DEMONSTRATE the flintlock ignition with a flint and steel.

DISCUSS how the caplock system improved on the flintlock system.

Fact sheet #1 – illustrations of lock types  
PASS AROUND small simulated samples of black powder, Black powder substitutes and smokeless powder in vials. **NO BLACK POWDER OR SUBSTITUTES IN CLASS ROOM**

REINFORCE the notion that low yield or low pressure is only in comparison to modern smokeless powder.

USE only Black powder in flintlock.

Screening not well done.

Competition shooters screen their own.

Fact Sheet #11

Fact Sheet #2

DEMONSTRATE the difference in burning rate between a FEW grains of black powder and a similar amount of smokeless powder.

2. Granule size controls burning rate
    - all explosively fast
    - Fg – 0 gauge or larger shotguns
    - FFg – shotguns, rifles .50 caliber and larger
    - FFFg – rifles under .50 caliber and pistols
    - FFFFg
      - flintlock priming or pan powder
      - NOT for main charge dangerous as main charge
  3. Proper storage and use essential
- C. Powder Substitutes like Pyrodex
1. One acceptable substitute for black powder in muzzleloaders
    - main charge in caplocks only
    - substitutes for equal VOLUME of black powder
    - Hodgdon 777
  2. Types
    - RS – rifles and shotguns
    - P – pistols
    - CTG – cartridges
    - C – cannons

### III. Projectiles

- A. Round Balls
- B. Conical Bullets
- C. Sabots

### IV. Types of Ignition

- A. Flintlock
- B. Percussion cap
- C. 209 shotshell primer

### V. Percussion caps

- A. Explosive mixture
  1. Detonates under pressure
  2. Damages by water or oil
- B. Copper or gilding metal cup
  1. Sizes not standard
    - rifles – size 10 or 11
    - snug fit on nipple
    - muskets all one size
  2. Danger from fragments

PASS AROUND samples or use illustrations to reinforce size differences.

Burning surface

STRESS the danger of using pan powder as a main charge.

DISCUSS the basics of safe storage REFER to next lesson for more information.

Pyrodex – select 30% more accuracy – more shots per pound – more corrosive.

NOTE that Pyrodex may not work well in flinters.

STRESS that equal volume, not weight, of Pyrodex gives equivalent performance. Fact Sheet showing actual grain size comparison. Example – gravel – sand – salt.

- burns cleaner and uses 10% less for equivalent velocity and pressure

*Fact Sheet #3*

- same hitting – maxi hunter – expands quicker

- maxi ball

- use only round balls

STRESS that percussion caps must be treated carefully – a heat and pressure sensitive explosive.

Heat pressure sensitive explosive compound.

*Fact Sheet #4*

(#11 or Musket cap)

DEMONSTRATE how caps should fit on the nipple.

REINFORCE the use of eye protection.

## VI. Muzzleloading arms

### A. Parts of a muzzleloader

#### 1. Lock

- lock plate
- mechanical parts of arm
  - hammer or cock - springs
    - main spring
    - sear spring
    - frizzen spring
  - tumbler
    - fly
    - bridle
  - sear
  - flintlock specialties
  - frizzen
  - flint
  - jaws
    - top jaw
    - bottom jaw
    - top jaw screw
  - flash pan
- trigger
  - trigger guard
  - trigger plate
  - trigger
    - single stage
    - set trigger

A lock to pass around.  
Fact Sheet #5

Works to release the sear which releases the mainspring which releases the hammer.

DISCUSS the type of trigger being used in the instructional sessions.

*Fact Sheet # 6: Trigger Types – how they work.* (1) Double Set (2) Single Squeeze rear trigger until click  
Creates hair trigger in front trigger.

#### 2. Stock

- “handles”
- butt stock
  - butt
  - comb
  - butt plate
  - patch box
  - wrist
- forend
  - wedge pin
  - escutcheons
  - forend cap

POINT OUT the parts of the stock and discuss their functions or use front alone

#### 3. Barrel

- muzzle
- breech plug
  - flintlock
  - flash hole
  - cap lock
- tang
- thimbles
- sights

ILLUSTRATE the types of breech plugs

SHOW various types of sights.

- open metallic sights
    - fixed (primitive)
    - Patridge-style
    - front bead and rear notch
  - receiver or peep
    - vernier peep
    - tang or barrel mounted
    - front bead or globe
  - tube sight
  - telescopic sights
4. Ramrod
- B. Types of muzzle loading arms
1. Pistols
    - muzzle loading pistols
    - multiple-barrel pistols
    - cap-and-ball pistols
  2. Rifles
    - rifled barrels
    - .22 to .58 caliber
    - .45 and smaller used for small game
    - .45 and larger used for big game
  3. Muskets
    - smooth bores
    - ball or shot
  4. Shotguns
    - designed for shot
    - with or without choke
    - single- and double-barrel designs
- **Muzzle loading accessories**
    - A. Shooter and hand loader at same time
      1. Equipment to load and fire
      2. Accessories to cure problems
    - B. Possibles bag
      1. Carrying bag for equipment
      2. Hold what might possibly be needed
    - C. Bullet handling
      1. Bullet board, loading block, bullet bag or shot pouch
      2. Bullet and/or patch lube
      3. Patch material
      4. Starter (short and long)
      5. Patch knife
      6. Wads for shotgunners
        - over-powder card
        - Felt
        - over-shot card
    - D. Powder
      1. Powder flask or horn

**IN 4-H WE NEVER USE A WOOD RAMROD TO LOAD WITH**

REVOLVER: most are cap and ball, regardless of action.

SHOW actual firearms or pictures of various types to give participants an idea of their variety.

NOTE that commonly available calibers run from about .45 to .58. *Fact Sheet #7*

Note: See page 11 – second paragraph

Empty a possibles bag on a table, SHOW the items that it contains. DISCUSS the functions & need for the items as they are identified.

REFER to film, “Black Powder, White Smoke

2. Priming powder flask or horn
  3. Powder measure
- E. Ignition aids
1. Percussion caps
  2. Capping tool
  3. Spare flint or nipple
  4. Revolver Capper
  5. Nipple wrench
  6. Nipple pick
  7. Small screwdriver

- F. Cleaning aids
1. Solvent
  2. Cleaning patches
  3. Cleaning jag
  4. Worm
  5. Ball puller
  6. CO2 discharger

## VI. Comparing muzzleloaders and cartridge arm

- A. Muzzleloading complex
1. Loading and shooting
    - knowledge of all operations
    - safety
  2. Returning to earlier technology
- B. Care and attention to learning

## VII. Summary

- A. History
1. Ignition systems
  2. Developments in arms
- B. Propellants
1. Black powder
  2. Black powder substitute
- C. Types of arms
1. Ignition systems
    - Flintlock
    - caplock
  2. Basic firearm parts
    - Lock
    - Stock
    - barrel
  3. Firearm types
    - Pistols
    - Rifles
    - Shotguns
    - muskets
- D. Accessories
1. Loading accessories and necessities
  2. Cleaning equipment
- E. Differences between muzzleloading & modern firearms
- F. Safety considerations in the next lesson.

## Fact Sheet #8: Accessories

## Fact Sheet #36: New System – CO2 Discharger – Bore Cleaner-bore butter

DISCUSS the differences between muzzle loading and cartridge arms. Compare checking to see if unloaded. Leave ramrod in barrel after checking.

Have participants REVIEW the content of the lesson using questions to REINFORCE the main points.

PREPARE them for the next lesson where safety will be the main thrust.

## Lesson Narrative 3

### History of Black Powder and Muzzleloading Arms

The history of muzzleloaders goes back to ancient China and the discovery of black powder. The mixture of sulfur, charcoal and saltpeter was used in fireworks for some time. The first written account of black powder was published in England in 1242 AP Roger Bacon. Within a few years a German monk, Berthold Schwartz, developed black powder for use as an explosive and a propellant for firearms. He is also thought to have developed the first European firearm early in the 14th century. Most 14th century firearms were hand cannons and larger artillery pieces. By 1346 cannons were used on the battlefield, but the longbow was still the basic war weapon.

The first black powder arms were fired by inserting a glowing wire into a touch hole. Next came a trigger-operated system that lowered a burning fuse or "slow match" into a priming pan charged with a small amount of fine powder. These matchlock arms, like the blunderbuss arms associated with the Pilgrims, were demanding. The hunter or soldier needed a source of flame, relatively calm wind conditions, dry weather and a still target. Matchlock arms were not very practical as either hunting or military arms, but they were the dominant arms from early in the 15th century to the middle of the 17th century.

Two designs that used steel sparks for ignition followed the matchlock. The wheel lock was a complicate and expensive design, which operated on the same principle as modern lighters. It was made by a clockmaker. It was complicated to make and had many small parts. It was a practical sporting arm, but the cost placed it out of reach of most people. A spring was wound and held in place by a sear.

When the trigger was pulled, the spring rotated a serrated steel wheel against a piece of iron pyrite creating a shower of sparks. The sparks ignited a priming charge of black powder that fired the main charge. Wheel locks had quicker ignition and were more reliable than matchlocks. The iron forge was used to make gun metal and metal forms for tools.

Flintlock arms had replaced most other types by the middle of the 17<sup>th</sup> century. Rather than using the complex clock works of the wheel lock, the flintlock used a spring to strike a flint against a hardened steel frizzen. The steel sparks were deflected into a priming pan, igniting a priming charge that ignited the main charge. Flintlocks were the standard for the next 150 years, and they continued to be widely used for 50 years after the introduction of the caplock.

The caplock was invented around 1820. An explosive mixture of fulminate of mercury enclosed in a copper *cup* provided the spark to ignite the main powder charge. The lock mechanism itself changed very little from the flintlock to the caplock. The cock became a hammer, often with a cupped head to control the direction of any copper fragments. Upon firing copper

#### Fact Sheet

Mechanical ignition systems operate together to form matchlock flame-wick.

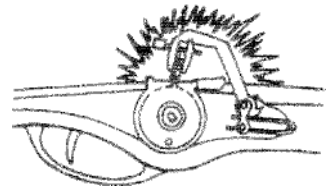
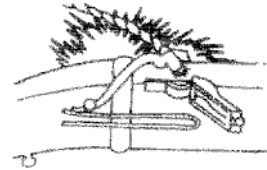

First Industry Grafton, N.H.

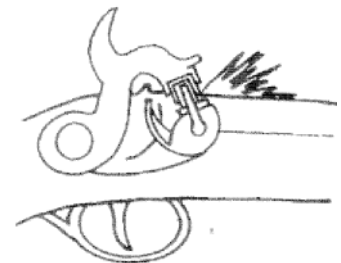
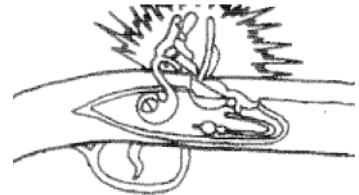

cap may rupture, and fragments may escape. The priming pan and frizzen were replaced with a nipple to hold the cap, and the cap took the place of the priming charge. Caplock or percussion arms were more weather resistant than flintlock arms, increasing their reliability. The age of percussion arms was relatively brief, because breech-loading arms with fixed ammunition followed rather quickly.

**Smokeless powders should NEVER be used. Excessive amounts of black powder can turn the firearm into a bomb, so follow manufacturer's recommendations on powder charges precisely.**

**FFFFg or four FG is very fine powder. It is never used as a main charge because it might produce dangerous results.**

## **Black Powder and Black Powder Substitutes**

Black powder and its substitutes are the only types of powder that should be used in muzzleloading firearms. Some examples of substitutes include Pyrodex and "777". Smokeless powders should NEVER be used. Smokeless powders generate pressures that are much too high for the open systems found in muzzleloading arms and their use may have catastrophic results.

Black powder is a low-yield explosive. That does not mean that it can be taken lightly or abused. It is quite powerful but produces pressures that are tolerable in firearms with an opening at the breech. Improper procedures in loading black powder can result in serious pressure problems that could cause damage to the firearm and/or the shooter or bystanders.

Black powder is black in color, but it is the composition of the powder rather than its' color that make it black powder. Most propellant powders are black or gray in color. The label should state both the type and granulation of the powder. DO NOT USE any smokeless powder in a muzzleloader even if the powder color is black.

Black powder has changed little in composition since its discovery. It is still a mixture of sulfur, charcoal and potassium nitrate (saltpeter). The mixture is ground into particles that are graded by granule size. Although all black powders burn explosively fast, the size of the granules control the burning rate and the use of the powder. Industry standards govern the size granules in each grade of powder. The coarsest sporting powder is Fg, or single Fg. It is used in shotguns 10 gauge or larger. Double Fg or FFg powder is finer. It is used in 12 gauge or smaller shotguns and rifles .50 caliber or larger. Triple F or FFFg powder is used in pistols and rifles under .50 caliber. It is finer and faster burning than FFg. It can be used as pan powder in flintlocks if necessary. FFFFg or four Fg is very fine powder. It is never used as a main charge because it might produce dangerous results. It is primarily used as priming or pan powder for flintlock arms.

Black powder is relatively unstable. It is sensitive to heat and pressure as well as sparks or flame of any kind. It is also hygroscopic – it absorbs moisture from the air. Wet powder does not ignite properly. Proper storage is essential for safety and containers must be closed between shots while on shooting range.

Pyrodex, a modern powder designed for use in muzzleloading arms, is manufactured by the Hodgdon Powder Company. Pyrodex is harder to ignite than black powder, so its use should be restricted to percussion arms. Pyrodex produces results like an equal volume of

black powder, so the same powder measure may be used for both types of propellant

## **Percussion Caps**

Percussion caps are open cups of copper or gilding metal containing a small amount of pressure sensitive explosive. Several compounds may be used to provide the spark, but all of them are explosive. They are sensitive to both pressure and heat, and they are all damaged by exposure to water or oil. Percussion cap sizes are not standardized among manufacturers, but usually rifles use size 10 or 11 caps. The cap should fit snugly on the nipple. Musket caps are all the same size. Some new muzzleloading rifles use a musket cap for ignition. **Always** check the rifle to determine the type of cap to be used. Since the caps are exposed to the pressure of their own firing plus that of the main charge going off, the lightly constructed metal cup may come apart during firing. The potential for flying cap fragments and the blow-back of gases from the nipple or flash hole increase the need for adequate eye protection when shooting muzzleloading firearms.

## **Muzzleloading Arms**

People often use "lock, stock and barrel" to describe the entire thing. That phrase originated from muzzleloading firearms. The lock contains the mechanical parts of the firearm. It's attached to a lock plate bolted to the stock of the firearm.

The lock consists of the hammer or cock, several springs, a tumbler and sear, and a bridle to hold the other parts in place. The hammer is driven by the main spring. The sear is controlled by the trigger and a sear spring. Flintlocks add a frizzen spring. The tumbler may contain a fly when set triggers are used.

Flintlocks have some special components. The hammer is replaced by a cock that holds the flint between top and bottom jaws. The flint is sharpened, its position is adjusted, and it is padded with a strip of leather before the top jaw is tightened by turning the top jaw screw. The frizzen is made of hardened steel to produce an abundant spark when struck by the flint. A spring holds it in place until it is struck by the flint. It then deflects forward, allowing the sparks to shower down into the flash pan.

The trigger mechanism is protected by a trigger guard, often an elaborate one in muzzleloading rifles. The trigger or triggers are set in a trigger plate. Some muzzleloading arms have a single stage trigger. Others feature set triggers, either a double-stage trigger or a set trigger and a firing trigger. Other triggers include set back trigger, front trigger and sensitive target trigger. Those with set triggers usually have an adjustment screw that sets the tension on the firing trigger.

The stock provides the handles for the firearm. The butt stock holds the firearm against the shoulder or hand. The butt of the

firearm often has a curved butt plate of brass, steel, horn or plastic. The side of the stock often has a hinged compartment, known as a patch box. The top edge of the butt stock is known as the comb. It provides a support surface for the face or cheek during firing. The grip area of the butt stock, usually just behind the tang or breech plug, is called the wrist. Some of the references may call it the grip or small.

The forend or forearm of the stock holds the barrel in place and provides a control surface for the forward hand. Many muzzle-loaders have a barrel wedge or wedge pin that inserts in a channel in the stock and runs through a slot in a barrel lug. In combination with a hooked breech, this holds the barrel to the stock. The sides of the slot or channel are guarded and reinforced by escutcheons, small metal plates inset into the stock. The end of the stock is often capped by a metal forend cap. Usually the internal structure of the stock and forend cap are milled out to accommodate the ramrod.

The barrel is similar to the barrels of other firearms except that the breech is closed by a plug. The arm is loaded through the muzzle, and the load is pushed down firmly against the breech. The breech plug is threaded firmly against the barrel. At the rear of the barrel, a threaded insert continuing the flash hole (flintlocks) or either a snail and nipple or drum and nipple arrangement (percussion) channels the spark into the powder charge. The rear of the breech plug inserts into a slot in the tang, which is a metal brace attached to the butt stock. The barrel may feature one or more thimbles, tubes that support the ramrod, on its underside. Usually the sights are mounted on the top flat of the barrel, although some types of rear receiver sights may be mounted on the tang. Telescopic sights may be used on muzzleloaders, but most feature some type of metallic sights. Primitive sights are simple notch and blade arrangements. Adjustments are usually made with a drift punch or file. Adjustable open sights usually feature either a Partridge-style square notch and blade or a bead and notch arrangement. Peep or receiver sights may be mounted on the tang or the barrel, and a front globe sight may be used in some cases. The ultimate in peep sights is the tube sight, which resembles a long telescopic sight without glass.

The ramrod is essential to shooting a muzzleloader. As a result, almost all muzzleloading long guns have a provision for mounting the ramrod while the gun is being carried. Ramrods may be made of metal, wood or synthetic materials. **IN 4-H WE NEVER USE A WOOD RAMROD FOR LOADING OR CLEANING.**

## **Types of Muzzleloading Firearms**

Muzzleloading shooters can use handguns, rifles, shotguns and muskets or trade guns. Muzzleloading pistols can have a single barrel, multiple barrels or a revolving cylinder that is loaded from the muzzle end. Cap-and-ball revolvers gave the black powder shooter additional firepower. Other types of muzzleloading pistols feature either caplock or flintlock design.

Muzzleloading rifles feature rifled barrels with a relatively slow twist. Although muzzleloading rifles may be located with barrels from approximately .22 to more than .60 caliber, the most common borings are .21, .36, .45, .50, .54 and .58. In general, .45 caliber and smaller arms are used for hunting small game. Rifles .45 caliber and larger are used in hunting big game. All of them can be used in target shooting. Muzzleloading rifles may fire round, patched balls, mini balls or a variety of newer, flat-based bullets.

Muskets are smooth-bored arms used with either a single projectile or a shot charge. They were often the arms of choice in military applications because they were easier and quicker to load than rifles. Muskets often have large bores, up to .69 caliber or larger.

Muzzleloading shotguns or fowling pieces are constructed with lighter barrels and designed to shoot charges of fine shot. They may be either single-barrel or double-barrel guns. Some modern muzzle loading shotguns have choked barrels to increase range and pattern density. Many muzzleloading shotguns are cylinder bore guns because that straight boring makes loading easier. These arms may be used in hunting or in target shooting games.

## **Muzzleloading Accessories**

Muzzleloader shooters must understand and perform the actions of modern handloaders and shooters for each shot. Greater care is necessary because the barrel is accessible only from the muzzle. The shooter must carry more equipment into the field. They must be prepared to load and fire and be prepared to solve any problems that may arise in ordinary use. Many muzzleloader shooters carry a possible bag, a leather pouch holding ALL the items they might possibly need for the day afield or on the range.

In addition to the balls, shot or bullets that will be used, the shooter needs a bullet pouch or bag to keep them under control. A bullet board or loading block with pre-lubed or patched bullets ready to be loaded may be helpful. Most shooters carry bullet lube or patch lubricant in their bags. If round balls are used, the shooter needs to have pre-cut patches of the appropriate type, size and thickness or patching material and a patch knife. Patches should be cotton or linen. Synthetic materials may foul the bore with residues that are very difficult to remove. A ball starter is needed to get the ball moving down to bore. The ball starter usually has both short and long shafts of starting the ball before using the ramrod. shotgunners need shot and a series of wads. The gases produced by the powder are contained with an over-powder wad. The shot is cushioned by lubricated fiber wad, and held in the barrel by a thin, card, over-shot wad. Some old-time shotgunners preferred paper from wasp nests for over-shot wads.

Flintlock shooters must carry two types of powder in separate flasks or horns. Since only small amounts of priming powder are needed,

*Fact Sheet #8:  
Accessories*

T/C handout

Regardless of the type of arm being used, powder must be carefully measured in a horn, brass or similar non-sparking material. Powder is never poured into the firearm directly from a horn or flask.

the priming flask or horn can be quite small. For safety reasons it should be distinctly different from the flask or horn containing the powder for the main charge. Users of percussion arms need only the single supply of powder, but they must have a supply of percussion caps. Regardless of the type of arm being used, powder must be carefully measured in a horn, brass or similar non-sparking material. Powder is never poured into the firearm directly from a horn or flask.

To fire the muzzleloader, the shooter needs tools and equipment for the appropriate type of ignition system. Flintlock shooters need spare flints and the tools necessary to change or sharpen and adjust flints in the field. Caplock shooters need percussion caps. A spare nipple is a wise precaution, and a capping tool makes capping easier and more consistent. A nipple wrench and a nipple prick or pick for cleaning out the small hole in the nipple is needed. Some shooters carry a piece of fine copper wire for this purpose, others prefer piano wire or similar stiff material. Flintlock shooters need a similar tool for cleaning fouling from the flash hole.

All shooters should carry equipment to clean their guns in the field. A combination patch lubricant and black powder solvent is an excellent choice. Cleaning patches, a cleaning jag to fit the bore and the jag and a worm for retrieving lost patches will all be needed. A ball puller is a necessity in case powder becomes fouled after loading or if a ball or bullet gets loaded without a powder charge.

### **Differences in Muzzleloading and Cartridge Arms**

Muzzleloader shooters need a possible bag for the little items that could quickly fill all their pockets. These items are vital to having a good time shooting. Muzzleloading is a lot more complex than shooting cartridge firearms. Muzzleloaders must know and practice all the elements of both loading and shooting safely. Returning to an earlier level of technological development in shooting demands more of the user. Care and attention to detail in learning this earlier technology is important. Develop sound basic habits and ask questions while learning to use these tools.

### **Summary**

In this session we explored the history of black powder and muzzleloading arms briefly. We followed the development of several types of ignition systems, from the matchlock and wheel lock to the flintlock and percussion arms more commonly seen today. We compare the basic parts of these arms with those of cartridge guns, noting that the lock, stock and barrel describe the basic components of muzzleloaders. We also noted that muzzleloading arms cover all types: pistols, rifles, shotguns and muskets. The shooter needs a wide array of accessories to load, fire and field clean their gun. Those accessories make shooting both easier and safer. The basics of muzzleloading safety will be considered next time.

### **Summary Activities**

1. Allow the participants to handle and study the materials used in the lesson.
2. If an adequate range is available, have an adult or teen leader load and fire a muzzleloader while the process is explained, and the equipment is described.
3. Play an identification game with the parts of the muzzleloaders and their accessories.

### **Exhibit or Sharing Ideas**

1. Develop posters showing the parts of a muzzleloader, including diagrams of various ignition systems.
2. Demonstrate the parts of a muzzleloader to an interested adult or another audience.
3. Demonstrate the use of muzzleloading accessories to an adult or another interested person.
4. Discuss the differences between shooting muzzleloading firearms and cartridge firearms of the same type.
5. Study the history of muzzle loading firearms or black powder. Relate that history in a report, illustrated talk or presentation to your shooting sports group.
6. Study the local history of muzzleloader or powder manufacturing. Relate that history to other historical events and period dress. Share your findings with an interested audience in your school or shooting sports group.
7. Reenactment of a local event or living history

# Shooting Muzzleloading Shotguns (Optional)

Jim Smith and Ronald A. Howard Jr.\*

---

## Objectives

Participating youth and adults will:

1. Practice proper shotgun shooting form using muzzleloaders.
2. Practice proper loading and firing of muzzleloading shotguns.
3. Practice cleaning muzzle loading shotguns.
4. Develop safe handling and range procedures with muzzleloading shotguns.
5. Have fun while learning.

## Roles for Teen and Junior Leaders

- Demonstrate loading, firing and cleaning procedures.
- Operate a trap.
- Oversee a shooting station as an assistant range officer.
- Assist young people experiencing difficulty with any phase of the lesson.
- Assist with cleaning operations.
- Conduct a fun shoot.

## Parental Involvement

- See Roles for Teen and Junior Leaders above.
- Arrange for or provide equipment.
- Arrange for or provide range or cleaning areas.
- Serve as range officers, scorers or assistants.
- Arrange for or provide transportation.
- Arrange for or provide refreshments.
- Discuss personal experiences.

\* Executive with Thomson/Center Arms and a member of the National

4-H Shooting Sports Committee, 4-H and Youth Development Specialist Texas Agricultural Extension Service.

## Best Time to Teach

Any time outdoor ranges may be used comfortably

## Best Location

Range and cleaning area

## Time Required

About 1 hour

## Materials/Equipment

- eye and ear protection
- muzzleloading shotguns
- nitro card wads (appropriate gauge)
- lubricated felt wads (appropriate gauge)
- over powder wads (appropriate gauge)
- powder and shot
- powder and shot measure
- percussion caps
- loading bench
- traps and clay targets
- cleaning equipment and supplies

## References

*National Muzzleloading Rifle Association Instructor Workbook.* National Muzzleloading Rifle Association, Friendship, IN.

*The Muzzleloading Shotgun Handbook.* J.W. Carlson and S. Davenport, eds. National Rifle Association and National Muzzleloading Association, Washington, DC and Friendship, IN. 1985.

*Manufacturer's catalogs and Instructional Handbooks.* State or provincial hunter education manuals. *Black Powder, White Smoke.* Video. Contact your state 4-H shooting sports coordinator or hunter education coordinator.

*Basic Shotgun Shooting Lesson Plans.*

# Teaching Outline

---

## Presentation

### I. Muzzleloading shotguns

- A. Comparison with modern shotguns
  1. Little or no choke
    - lower pattern density
  2. Lower velocity
    - more lead
    - shorter effective range
- B. Shotgun characteristics and types
  1. Smoothbore
    - Shotguns
    - Muskets
    - trade guns
  2. No rear sight
  3. Single trigger for each barrel
  4. Single barrel or double-barrel models.
  5. Bore diameter measured by gauges
    - now standardized
    - number of lead balls of bore diameter cast from a pound of lead

### II. Muzzleloading shotgun safety

- A. All firearms handling rules apply
  1. Eye and ear protection
  2. Self-control necessary
  3. Muzzle control necessary
  4. Trigger control necessary
  5. Not loaded until ready to shoot
  6. Target identification essential
  7. Safety of shot is shooter's responsibility
- B. Black powder handling rules
  1. Avoiding sparks or flame
  2. Loading from separate measure
  3. Proper handling and storage
  4. Safe loading procedure needed
- C. Safety rules of each shotgun sport apply

## Application

DISCUSS features of muzzleloading shotguns that make them different from breech-loading shotguns. STRESS those features that alter range, pattern density or shooting process.

Some barrels are equipped with screw in choke tubes

*Fact Sheet #19.*

DEMONSTRATE and DISCUSS each type and their features. EMPHASIZE type of shotgun used in this session.

ILLUSTRATE how gauge was determined using musket balls.

LEAD shooters in DISCUSSION of basic rules of safe firearms handling. STRESS all cardinal rules and use of eye and ear protection.

REVIEW rules for handling black powder safely

### III. Loading muzzleloading shotgun

#### A. Powder

##### 1. Granulation

- 10 gauges – Fg
- 12 to 20 gauges – FFg
- 20 gauges or smaller - FFFg

##### 2. Powder charge

- drams or grains
  - drams
    - apothecary volume
    - dram equals 27<sup>1</sup>/<sub>2</sub> grains
  - grains
    - 1/7000 pound
    - graduations on powder measures
- Rule of thumb equal volume of shot and powder

#### B. Over-powder wad

1. Thin nitro card wad
2. 2 to 3 mm (1/16 to 1/8 inch) thick
3. Seals gases into bore

#### C. Felt or fiber wad

1. Soaked or lubricated
2. 6 to 18 mm (1/4 to 3/4 inch) thick
3. Cushions shot during firing
4. Plastic unit wad not recommended
  - possible build up in bore
  - may void warranty

#### D. Shot charge

1. Pure lead best
2. One size larger than in modern shot shells
3. Steel shot

#### E. Over-shot wad

1. Very thin nitro card
2. Very thin cardboard
3. Wasp nest material

#### F. Suggested loads

1. Follow manufacturer's recommendations
2. Starting loads

DISCUSS proper powder selection for different gauges of muzzleloading shotguns

Pyrodex RS can be used in all shotgun gauges.

NOTE that dram measure is a volume measure while most powder measures are graduated in grains

Use grain weight charges

SHOW selection of wads that will be used and DISCUSS their functions.

Best method

NOTE that fiber wad should be lubricated like patches used with rifles.

STRESS reasons for not using plastic unit wads

NOTE that soft lead shot will give wider patterns than chilled, or magnum shot. COMMENT on reason for increasing shot size in hunting situations.

#8's or #9's are best for breaking clay targets

T/C shotguns can use steel shot

Check instruction manual for other brands

DISCUSS suggested loading combinations and need to stay within limits set by shotgun maker.

- 10 gauge
    - 89 gr. Fg (3<sup>1</sup>/<sub>4</sub> dram)
    - 1 <sup>1</sup>/<sub>4</sub> ounces shot
  - 12 gauge
    - 76 gr. FFg (2<sup>1</sup>/<sub>4</sub> dram)
    - 1 <sup>1</sup>/<sub>8</sub> ounces shot
  - 16 gauge
    - 61 gr. FFg (2<sup>1</sup>/<sub>4</sub> dram)
    - a ounce shot
  - 20 gauge
    - 55 gr. FFg (2 dram)
    - <sup>3</sup>/<sub>4</sub> ounces shot
  - 28 gauge
    - 47 gr. FFFg (1<sup>3</sup>/<sub>4</sub> dram)
    - <sup>3</sup>/<sub>4</sub> ounces shot
3. Heavy field loads
- 10 gauge
    - 109 gr. Fg (4 dram)
    - 1 <sup>3</sup>/<sub>4</sub> ounce shot
  - 12 gauge
    - 89 gr. FFg (3<sup>1</sup>/<sub>4</sub> dram)
    - 1 <sup>1</sup>/<sub>4</sub> ounce shot
  - 16 gauge
    - 76 gr. FFg ( 2<sup>3</sup>/<sub>4</sub> dram)
    - 1 <sup>1</sup>/<sub>8</sub> ounce shot
  - 20 gauge
    - 69 gr. FFg (2<sup>1</sup>/<sub>2</sub> dram)
    - 1 ounce shot
  - 28 gauge
    - 61 gr. FFFg (2<sup>1</sup>/<sub>4</sub> dram)
    - 1 ounce shot
4. Work up loads carefully
- change only one component at a time
  - record performance
  - stay within manufacturer's limits

#### IV. Loading procedures

- I. Basic precautions apply
- II. Set measure or use scoop for light powder and shot charge
- III. Swab bore
  1. Alcohol moistened patch
  2. Dry patch

EMPHASIZE need to develop effective loads from light side to achieve optimum performance. STRESS keeping all but one component same and recording the results.

DEMONSTRATE proper loading technique on one of shotguns being used in this session. DISCUSS each step as it is performed.

REINFORCE all actions to keep loading process orderly to avoid loading errors

- IV. Clear nipple or flash hole
  - 1. Fire several caps
  - 2. Use nipple pick
  - 3. Use pipe cleaner
- V. Charge with powder
  - 1. Proper granulation and amount
  - 2. Avoid double charging
    - keep ramrod in empty barrel of doubles
    - load one barrel at a time
- VI. Seat over-powder and fiber wads
  - 1. Seat firmly
  - 2. Release ramrod and watch for any rebound
  - 3. Repeat until wads stay tightly on powder
  - 4. Move ramrod to empty barrel
- VII. Charge with shot
  - 1. Measure shot charge
  - 2. Pour shot in barrel
- VIII. Seat over-shot was
  - 1. Seat firmly on shot
  - 2. Avoid excessive pressure
  - 3. Watch for ramrod rebound
  - 4. Repeat until secure
- I. Shift ramrod to loaded barrel
- J. Load second barrel
- K. Cap or prime

**V. Shooting muzzleloading shotguns**

- A. Shotgun shooting form
  - 1. Boxer's stance
  - 2. Elbows out for easy movement
  - 3. Mount
    - consistency important
    - bringing shotgun to check
  - 4. Swing to target
  - 5. Establish lead
  - 6. Fire
  - 7. Follow through
- B. Considerations for muzzleloading shotguns
  - 1. Little or no choke cylinder bore
  - 2. Lower velocities
  - 3. More lead or more pronounced follow through
  - 4. Lower pattern density and shorter range

DEMONSTRATE ramrod rebound and need to seat wad completely.

NOTE that excessive pressure can damage shot, but charge must be FIRMLY seated.

REVIEW fundamentals of shotgun shooting briefly.

REFER to basic shotgun shooting lessons for details and procedures if shooters are new to shotgun shooting.

For experienced shotgun shooters, STRESS need for some adjustments in shooting mechanics.

### C. Range management

1. Load only when preparing to fire
2. Cap or prime after getting on the station or firing line
3. Misfires or hang-fires
  - muzzle down range for two minutes
  - muzzle in safe direction while treating problem
  - handle as with rifles
    - use wad puller to remove wads
    - exercise same caution
4. Cease fire
  - temporary
    - remove cap or priming powder
    - cover nipple or frizzen and flash hole
  - end of shooting
    - wait for “dump it in the hill” command
    - discharge in safe direction
5. Standard range commands and operation
6. Shotgun lessons for shooting skill development

### VI. After the shooting

- a. Collect and store any equipment
- b. Clean shotgun thoroughly
  1. Remove barrel(s) from stock
  2. Remove nipple from breech
  3. Remove lock(s)
  4. Scrub thoroughly with soapy water or black powder solvent
  5. Rinse with hot water
  6. Dry thoroughly
  7. Wipe or swab with alcohol patch
  8. Treat with gun oil or other moisture protectant
  9. Re-assemble firearm

DISCUSS proper range behavior (see basic shotgun shooting lessons).

REINFORCE the notion that shotguns are only capped or primed after shooter is on stand and prepared to fire.

DISCUSS how to handle misfire or hang-fire.

STRESS importance of emptying shotgun when shooting is finished.

Have shooters ASSIST with collecting and putting away any loading and shooting equipment.

LEAD them in cleaning shotguns carefully and preparing them for storage.

- C. Store muzzle down
  - 1. Check condition and clean again if needed in 24 hours
  - 2. Dry. Secure storage area

## VII. Summary

- A. Muzzleloading shotguns
  - 1. single or double barrels
  - 2. Percussion and flintlock
  - 3. Shotguns, trade guns and muskets
- C. Loading like rifle loading
  - 1. Powder
  - 2. Over-powder and fiber wads
  - 3. Shot
  - 4. Over-shot wad
  - 5. Complete seating of wads and shot on powder
  - 6. Loading system to keep things straight
- D. Shooting like other shotguns
  - 1. Lead and follow through more critical
  - 2. Range shorter
  - 3. Need for larger shot to adjust for lower shot velocity
- E. Cleaning
  - 1. Process as with rifles
  - 2. Immediate cleaning necessary
  - 3. Storage in dry, secure place

LEAD a REVIEW of shotgun shooting lesson using questions to stimulate in reinforcing main points of lesson.

## Lesson Narrative (Optional)

---

### Muzzleloading Shotguns

Modern shotguns and muzzleloading shotguns share most characteristics. Both types of firearms have smooth bores designed to fire multiple projectiles at moving targets. They share basic components like a stock, barrel and action or lock. Some manufacturers offer screw-in choke tubes. These cylinders bore guns shoot wide patterns with low-pattern density by modern standards. The loads often produce slightly lower muzzle velocities, which may tighten the pattern slightly. Effective range is reduced because of the low-pattern density and lower pellet energy. That loss of velocity also requires a slight increase in leads and increases importance of a strong follow through.

Bore size is standard but barrel ID may vary between manufacturers. US made are the same as 12g standard but foreign barrels may vary

Muzzleloading shotguns come in several varieties. Shotguns were designed specifically for shooting at moving game. **Trade guns** were inexpensive smoothbores that were traded with the Indians during the height of the fur trade. They were used with either a single ball or with shot. **Muskets** were smoothbore military arms that could be used with shot or a large round ball. Shotguns and trade guns have no rear sight. They are pointed like a modern shotgun. Rather than a set trigger arrangement often seen in rifles, they have a single trigger for each barrel. Both single-barrel and double-barrel shotguns are available.

As with modern shotguns, bore size is now standard for different gauges. Gauge was determined by the number of bore-diameter balls that could be cast from a pound of lead. Standardized gauge diameters make obtaining proper wads relatively easy

### Muzzleloading Shotgun Safety

All the fundamental rules of safe firearms handling also apply to muzzleloading shotguns. Everyone on the range must wear eye and ear protection. Shooters and bystanders must exercise self-control at all times. The muzzle must be pointed in a safe direction at all times, never at anything the shooter does not want to shoot. Never place fingers on the trigger until ready to fire, and do not load the shotgun until ready to shoot. Cap the percussion lock or prime the flintlock only when on the shooting station or firing line. In the field, the shooter is responsible for proper and complete target identification. The responsibility for the safety of any shot rests with the shooter.

All the fundamental safety rules for handling black powder and muzzleloading arms apply. Minimize exposure of the body to risk. Avoid flames or sparks. Load from a separate powder measure that yields a carefully measured charge of the proper powder granulation. The powder must be stored and handled safely at all times. Finally, practice a sound and safe loading procedure every time.

In addition to these general rules, the rule of any shotgun shooting game must be followed. That is particularly true of any rules that pertain to the safety of the shooter, range personnel and bystanders.

## Loading Muzzleloading Shotguns

Appropriate power granulation changes with the bore diameter of the shotgun. Ten-gauge guns use Fg powder. Shotguns from 12 gauges to 20 gauges should use FFg. Shotguns 20-gauge or smaller should use FFFg. Note that the 20 gauges may be loaded effectively with either FFg or FFFg.

Powder charges for shotguns are commonly expressed in drams of black powder. The dram is a unit of volume used in the past for apothecary or pharmaceutical measure. Modern shot shells refer to the dram-equivalent of their smokeless powder charge. Although the historical measure is in drams, most powder is now measured in grains. One dram is equal to 27.5 grains and one grain weighs 1/7000 of a pound. A basic rule of thumb for shotgun shooting is to use equal volumes of powder and shot. The light, starting loads suggested here approximate that rule of thumb. All shotgun gauges may successfully use Pyrodex RS. Pyrodex should not be used in flintlock shotguns. Follow manufacturers suggested loading information usually describes in gr weight.

A set of wads is used to seal the gases behind the shot and to cushion the shot as the charge is fired. The over-powder wad is a thin, nitro card wad. Wads about 2 to 3 cm ( $1/16$  to  $1/8$  inch) thick are a good starting point. A felt or fiber wad treated with a lubricant or soaked in water or solvent is seated on top of the nitro wad. Felt wads 6 to 18 cm ( $1/4$  to  $3/4$  inch) thick work well. All wads should fit the bore tightly and be seated firmly on the powder or shot.

Plastic wads are *not* recommended. They may leave a buildup of plastic material in the bore, and some manufacturers will not honor a warranty if plastic wads have been used in their shotguns.

The shot charge should be within the manufacturer's recommended limits for the shotgun. Most field shooters tend to use one shot size larger than they would normally use in a breech-loading shotgun when hunting. The heavier shot is used to partially compensate for the slightly reduced muzzle velocity and lower pellet energy. Maximum pattern dispersion is achieved with soft shot or drop shot. Chilled lead or magnum shot produce somewhat tighter patterns. Most manufacturers do not recommend soft iron or steel shot for muzzleloading shotguns.

The load is completed by seating a thin card wad to hold the shot in place. Very thin nitro wads (split nitro wads) or wads cut from thin cardboard work well. Some shooters prefer paper from wasp nests.

Suggested loads start with an approximate equivalent of maximum target loads. The 10-gauge load is 89 grains of Fg (about  $3\ 1/4$  drams) and  $1\ 1/4$  ounces of shot. A heavy load in the 10 gauges might go as much as 109 grains of Fg (4 drams) and  $1\ 3/4$  ounces of shot. The 12 gauge uses FFg powder- 76 grains ( $2\ 3/4$  drams) in the light load behind  $1\ 1/8$  ounces of shot and 89 grains ( $3\ 3/4$  drams) in the heavy load behind  $1\ 1/4$  ounces of shot. In the 16 gauge the starting load features 61 grains of FFg ( $2\ 1/4$  drams) behind 1 ounce of shot.

Plastic wads are not recommended.

The 20 gauge uses about 55 grains of FFg (2 drams) with a  $\frac{3}{4}$  ounce shot charge up to 69 grains ( $2\frac{1}{2}$  drams) of FFg and a 1 ounce shot charge. The little 28 gauges can drive a target load of  $\frac{3}{4}$  ounce of shot with 47 grains of FFFg ( $1\frac{3}{4}$  drams) or shoot a heavy charge of 1 ounce of shot with a 61 grain powder charge. Remember to start with the lighter loads and work up to the most effective load for your purpose. Change only one component at a time and record the results of each shot. Do not exceed the manufacturer's published limits.

## **Loading Procedures**

Remember that all the basic precautions for loading muzzleloaders apply to shotguns. Minimize the exposure of your hands, head and body to the muzzle. Minimize the amount of powder exposed at any time. Keep the muzzle pointed in a safe direction at all times and establish a standard loading process that will keep your loading safe.

Start by setting your measure and/or selecting a scoop that will deliver the proper powder and shot charges. Then check the shotgun to see that it is empty and safe. Swab the bore with an alcohol moistened patch. Use a dry bore mop or patch to dry the bore completely. Clear the nipple by firing several caps (muzzle pointed in a safe direction and watching for gas movement at the muzzle) or clear the flash hole with a pipe cleaner. If a flintlock is being used, wipe the frizzen, pan and flint with alcohol and dry them thoroughly.

Pour the proper amount of powder into the measure or scoop. Cap the container and pour the powder into the barrel. If a double barrel is used, place the ramrod in the empty barrel to avoid double charging one side. Seat an over-powder wad and a lubricated fiber wad firmly on the powder. Release the ramrod and watch for it to rebound. If it does, apply more pressure to seat the wads completely on the powder. Repeat this process until the ramrod stays in place. Place the ramrod back in the empty barrel, then measure the proper shot charge and pour it into the barrel. Insert an over-shot wad and ram it home firmly as before, watch for any rebound on the ramrod. The charge should be firmly in place, but do not bang on it or use excessive pressure. That will only deform the shot and produce erratic patterns. Once this barrel is loaded, transfer the ramrod to the loaded barrel and repeat the process with empty one. Once the barrels are loaded, replace the ramrod and wait your turn on firing line. Do not cap or prime the shotgun until you are on the shooting station or firing line. Maintain proper muzzle control always.

## **Shotgun Shooting**

Shotgun shooting form involves an aggressive, boxer's stance. The weight is shifted forward and the body leans into the shot until the head is over the front foot. The elbows are held nearly parallel to the ground to provide better freedom of movement. The shotgun is brought to the face and shoulder in a consistent mount. When the target appears, the shooter swings to the target, establishes a lead, fires and follows through. *[Instructor's note: consult the basic shotgun shooting lessons for these fundamentals if the shooters are not familiar with sound shotgun shooting form.]*

Muzzleloading shotguns place some limit on the shooter. The combination of cylinder bore patterns and lower velocity reduces their effective range on targets or game. Target or game birds will require slightly more lead and a more pronounced follow through for consistent hits. In field situations, the shooters may need to restrict their shooting to closer shots than would be possible with a tightly choked breech-loading gun.

## Range Management

Standard range commands should govern shooting on the firing line. [See the shotgun lesson plans for additional information.]

Since loading requires more time with muzzleloaders than with breech-loading shotguns, the shotgun maybe charged with powder and shot prior to reaching the shooting station IF it can be done safely and with the muzzle pointed away from all other persons. The shotgun should NOT be capped or primed until the shooter is in position and ready to call for the target.

Misfires or hang-fires should be treated as they were with muzzleloading rifles. Keep the muzzle pointed down range with the shotgun held on the shoulder for at least two minutes. Disable the shotgun by removing the caps or priming powder and shielding the nipple or frizzen. Keep the muzzle pointed in a safe direction while treating the problem. Use the sequence of actions described with muzzleloading rifles to dispose of the reluctant charge. On a temporary cease fire, disable the shotgun. Remove the cap or priming powder. Cover the nipple or frizzen with leather and lower the hammer into fired position. Insert a pipe cleaner into the flash hole of the flintlock for added security. At the end of a shooting session, empty the shotgun in a safe direction.

## After Shooting

After the firearms are emptied, collect and store all equipment. Arrange the shotgun cleaning materials in a convenient place and prepare to clean the shotguns. Remove the barrels and locks from the stock, and remove the nipples from the barrels. Scrub the barrels and locks thoroughly with hot, soapy water using a bore mop or cleaning jag and patches. Rinse them with hot water and dry them with dry patches, alcohol-moistened patches and additional dry patches. Lightly oil the inside of the bore and all metal surfaces, wiping away any excess oil. Reassemble the firearm and store it in a dry, secure area. Many shooters like to inspect their muzzleloaders again after about 24 hours, cleaning it once more if necessary,

**The shotgun should NOT be capped or primed until the shooter is in position and ready to call for the target.**

**. . . Keep the muzzle pointed in a safe direction while treating the problem.**

## Summary

Smoothbore muzzleloaders come in several varieties - musket, trade gun and shotgun in either percussion or flintlock designs. Shotguns are available in single-barrel or double-barreled designs. Shotgun safety and loading are very similar to the practices used with rifles. The shooter loads a measured powder charge, a pair of wads (over powder and lubricated fiber), a shot charge and an over-shot wad, seating the entire load firmly. A standard loading system is used to keep everything straight, and the ramrod is used as a signal device in doubles to help the shooter remember which barrel is being loaded at the time.

Shooting muzzleloading shotguns is much like shooting breech-loading shotguns. Lead and follow through are a bit more critical. Cylinder bore guns have a shorter effective range and shot size may need to be increased slightly to add killing effectiveness on game. Shooting form, however, is the same.

Shotguns are cleaned much like rifles, and immediate cleaning is essential. Storage considerations are the same as for other firearms.

## Summary Activities

1. Have shooters shoot several clay targets with muzzleloading shotguns. Then they should clean and prepare the arms for storage.
2. Introduce a shotgun game, either formal ones like trap or skeet or informal ones like riverside skeet or clover clays. Have the shooters fire one round of the selected game.
3. Use muzzleloading shotguns to complete basic shotgun lessons.
4. Hold a shoot or tournament where only muzzleloading shotguns maybe used.

## Exhibit or Sharing Ideas

1. Demonstrate or discuss muzzleloading shotgun safety, shooting or cleaning in an appropriate setting,
2. Record the things you learned in this session in your shooting journal. Exhibit the journal in an appropriate event or activity.
3. Demonstrate or give an illustrated talk on some aspect of muzzleloading shotgun shooting.
4. Prepare a set of posters on muzzleloading shotgun shooting, cleaning or safety for exhibition and posting at the host club or range.
5. Research the history of muzzleloading shotguns or shotgun sports and report them back to your group or another interested person.

# Shooting Muzzleloading Handguns (Optional)

Jim Smith and Ronald A. Howard Jr. \*

## Objectives

Participating youth and adults will:

1. Understand and demonstrate safe loading procedures for muzzleloading pistols.
2. Practice safe loading and firing of muzzleloading pistols.
3. Demonstrate proper cleaning of muzzleloading pistols.
4. Have fun while learning.

## Roles for Teen and Junior Leaders

- Demonstrate loading procedure.
- Demonstrate operation of the firing line.
- Serve as a range assistant at one firing point.
- Assist shooters with loading or pistol handling.
- Tutor any shooter needing special assistance.
- Conduct a fun shoot.

## Parental Involvement

- See Roles for Teen and Junior Leaders above.
- Arrange for or provide equipment.
- Arrange for or provide range and cleaning space.
- Arrange for or provide refreshments.
- Share personal experiences.

\* Executive with Thomson/Center Arms and a member of the National 4-H Shooting Sports Committee; and 4-H and Youth Development Specialist, Texas Agricultural Extension Service.

## Best Time to Teach

Any time outdoor range use is comfortable

## Best Location

Safe range and cleaning area with water available

## Time Required

About 1 hour

## Materials/Equipment

- eye and ear protection
- pistols
- pistol loading stands
- loading bench
- powder
- patches
- patch lubricant
- Balls
- pistol rod
- percussion caps
- nipple pick
- alcohol
- cleaning bucket
- brush
- soap
- gun oil
- black powder solven
- assembly tools

## References

*National Muzzleloading Rifle*

*Association Instructor Workbook.*

National Muzzleloading Rifle

Association, Friendship, IN.

*The Muzzleloading Rifle Handbook* J.W.

Carlson and S. Davenport, eds.

National Rifle Association and

National Muzzleloading Rifle

Association, Washington, DC and

Friendship, IN. 1985.

*Manufacturer's catalogs and instructional handbooks.*

*State or provincial hunter education manuals.*

*Black Powder, White Smoke.* Video.

Contact your state 4-H shooting sports coordinator and state hunter education coordinator.

*Basic Pistol Shooting Lessons*

# Teaching Outline

---

## Presentation

## Application

### I. Muzzleloading handguns

#### A. Single-shot pistol

1. Like rifle in design
  - percussion and flintlock designs
  - shorter barrel
  - butt stock replaced by pistol grip
2. Operation compared to rifle
  - loading process
  - firing
  - differences
    - loading stand
    - hold for firing

COMPARE design and function between muzzleloading pistols and rifles.

NOTE these significant differences.

DEMONSTRATE use of loading stand and proper shooting position.

#### B. Uses of muzzleloading handguns

1. Target shooting
2. Recreational shooting
3. Re-enactment activities
4. Small game hunting

DISCUSS some types of shooting that may be done with these arms

### II. Muzzleloading handgun safety

#### A. Handling safety

1. Short barrel
  - muzzle control critical
  - undivided attention essential

REVIEW fundamentals of handgun safety. (See basic handgun shooting lessons for detail if necessary.)

#### B. Powder handling and loading safety

1. Black powder or black powder substitute
  - correct granulation
  - charge within limits set by manufacturer
  - no sparks or flame
  - powder exposure minimum
2. Loading safety
  - minimal exposure of head, hands and body
  - use of loading stand
  - use separate powder measure
  - seat ball firmly

REVIEW proper powder handling and loading safety precautions.

ASK shooters to REVIEW safety precautions for loading muzzleloaders.

- C. All shooting safety and range control rules apply
1. Muzzle in a safe direction
  2. Loaded only when ready to fire
  3. Finger off trigger until ready to shoot
  4. Safe zone of fire and backstop
  5. Personal responsibility and self-control

### III. Loading and firing muzzleloading pistols

- A. Loading procedure same as for rifle
1. Ensure pistol is empty
  2. Position pistol in loading stand
  3. Swab bore with alcohol patch
  4. Dry bore with patch
  5. Clear nipple or prepare flint, frizzen and pan
    - percussion
      - fire several caps
      - check nipple channel
    - flintlock
      - wipe flint, frizzen and pan with alcohol patch
      - dry with clean patch
      - clear flash hole with pipe cleaner.
  6. Drop powder charge
    - proper granulation
    - proper amount
    - separate measure
  7. Seat ball
    - lubricated patch
    - ball centered with sprue up
    - start with short starter
    - seat completely with long arm of pistol rod
  8. Cap or prime

REVIEW range and shooting safety rules. (*Fact Sheet #17: Pistol and Rifle Shooting Procedures* if needed.)

DEMONSTRATE proper loading procedure for single-shot muzzleloading handguns being used in this session.

DISCUSS each part of operation as it is being demonstrated.

B. Firing process like other pistols

1. Stance
  - one-handed target grip
  - square two-handed grip
2. Firm grip
  - one-handed grip
  - two-handed grip - thumb-lock - palm-rest
3. Cock with off hand
4. Obtain proper sight alignment
5. Raise hands to firing position
6. Obtain sight picture
7. Press trigger
  - maintain sight alignment
  - maintain sight picture
  - steady pressure
  - straight back on trigger
8. Follow through

C. Handling misfires or hang-fires as with rifles

1. Keep muzzle down range for two minutes
2. Deactivate pistol
  - remove percussion cap or priming powder
  - cover nipple or frizzen with leather
  - lower hammer gently
3. Check seating depth
  - no powder
    - work small amount into flash hole or nipple and attempt to fire
    - pull ball and load properly
  - powder in load
    - check nipple channel or flash hole and attempt to shoot again
    - work fresh powder into nipple or flash hole and attempt to fire
    - pull load and start over
      - deactivate powder
      - clean and dry bore
      - reload and fire

(Refer to basic pistol shooting lessons if needed.)  
DEMONSTRATE each part of basic pistol shooting, firing pistol that was just loaded.

DISCUSS each step as it is accomplished

REINFORCE using these fundamental steps.

REVIEW and DISCUSS ways of handling misfires or hang-fires.

DEMONSTRATE how to deactivate pistol, following instructions from shooters.

REINFORCE steps to be taken in emptying misfired pistol.

- D. Cleaning muzzleloading pistols
  - 1. Clean as for rifle
  - 2. Store in dry, secure location
    - reassemble
  - 3. After shooting
    - clean all metal parts with hot, soapy water or black powder solvent
      - thorough cleaning essential
      - special attention to moving parts
    - follow manufacturer's instructions

REVIEW cleaning process with shooters by providing descriptions.

CLEAN all firearms used in session as final activity of session.

EMPHASIZE need for very thorough and frequent cleaning.

#### IV. Summary

- A. Handgun types
  - 1. Single-shot pistol
- B. Handgun safety
  - 1. Powder handling safety
  - 2. Muzzleloading safety
  - 3. Pistol shooting safety
- C. Shooting and cleaning handguns
  - 1. Muzzleloading pistol
  - 2. Cap-and-ball revolver
- D. Uses of black powder handguns
  - 1. Target shooting
  - 2. Recreational shooting
  - 3. Re-enactments
  - 4. Plinking or small game

ASK shooters to REVIEW what they have learned in session. Be prepared to DISCUSS any questions or ideas they may introduce.

## **Lesson Narrative (Optional)**

---

### **Black Powder Handguns**

The most common types of black powder handguns are single-shot pistols and cap-and-ball revolvers. The pistol is like a muzzleloading rifle in design and function. The main differences are the design of the stock and the length of the barrel. The pistol is designed to be held in the hands rather than on the shoulder, and the barrel is much shorter.

Pistols are available in both percussion and flintlock designs. They are loaded and fired like rifles using the same ignition system. The primary differences are the use of a loading stand, a device to hold the pistol in place while it is being loaded, and the way the pistol is held for shooting.

Muzzleloading handguns are used in target shooting, recreational shooting, re-enactments and in small game hunting. Their use on big game or larger small game animals is not recommended.

### **Muzzleloading Handgun Safety**

As with other muzzleloading arms, the muzzle loading handgun shooter must follow all the safety rules for loading and shooting handguns. Handguns require greater attention than shoulder arms to prevent unsafe situations from developing. The short barrel is easily moved about, so attention to muzzle control is essential. This requires undivided attention. No part of the body should be forward of the cylinder after it has been loaded.

The basic rules for safe handling of black powder must be followed during loading. Shooters must be sure the powder is the correct type or granulation. They must use a charge within the limits defined by the manufacturer. The amount of powder exposed must be kept to a minimum, and the loading and firing area must be free from sparks or flame. Black powder must be loaded from a measure separate from the powder can, flask or horn.

During the loading process the shooter must minimize exposure of head, hands and body to risk. The muzzle must be pointed down range slightly and away from all persons. A loading stand helps ensure safe loading. It holds the pistol securely in place and acts as a third hand during loading. Powder is carefully measured, and the patched ball or tight-fitting ball is seated firmly on powder.

All range control and shooting safety rules apply to this situation as well. Shooters must keep the muzzle of the firearm under control always, ensuring that it is pointed in a safe direction. Load only when the range is clear, and you are preparing to fire. The cap or priming powder is put in place just before firing a shot. The trigger finger stays off the trigger and covers the trigger guard until the shooter is ready to fire. A safe zone of fire and adequate backstop should always be determined before firing. Safety is the personal responsibility of every shooter, and self-control is the key to responsible shooting.

## **Loading and Firing Muzzleloading Pistols**

Single-shot muzzleloading pistols load just like rifles. The first step in loading is to ensure that the pistol is empty. Make sure that the pistol is deactivated (no cap on the nipple or priming powder in the pan) and check the barrel with a pistol rod. Fix the pistol securely in the loading stand. Swab the bore with a patch moistened with alcohol, then use a dry patch to clean and dry it. Clear the nipple by firing several percussion caps or clean the frizzen, flint and pan with alcohol, dry them thoroughly and clear the flash hole with a pipe cleaner. Measure and load the powder charge using a measure separate from the stock container. Be sure the granulation and powder charge are correct. Place a lubricated patch on the muzzle of the pistol, center a ball in the muzzle with the sprue facing up and start the ball into the bore with the short starter. Use the long arm of the pistol rod to seat the ball completely on the powder. Remove the pistol from the loading stand, being careful to keep the muzzle in a safe direction. After taking a position on the firing line, cap or prime the pistol and prepare to fire.

Shooting a muzzleloading pistol is much like shooting any other pistol. The shooter must take a proper stance for the grip being used – square to the target for a two-handed grip and with the shoulder pointing toward the target for a one-handed grip. The grip should be firm. Target shooters normally use a one-handed grip, shooting from the dominant side. Recreational shooters often prefer to use a thumb-lock grip or a palm-rest grip with both hands. Cock the pistol with the off or non-dominant hand. Align the sights, raise the pistol into firing position and obtain a proper sight picture. Squeeze or press the trigger straight back while keeping the sights aligned and maintaining the proper sight picture. Hold the sight alignment through the shot in the follow through.

Misfires or hang-fires should be handled as they were with rifles. Start by keeping the pistol pointed down range for at least two minutes. Deactivate the pistol by removing the cap or pan powder, covering the nipple or frizzen with leather and lowering the hammer gently into the fired position. Check the seating depth of the ball to determine the pistol's status.

If the *pistol* has been loaded without powder, two options may be tried. A few grains of powder may be worked into the barrel through the nipple or flash hole to shoot the ball free. Another method is to use a short work rod with a ball puller to pull the ball and permit loading properly.

If the pistol is properly loaded, a series of steps should be tried. First, after checking to see that the ball is properly seated, inspect and clean the nipple or flash hole, frizzen and flint. Prime the pan or place a cap on the nipple and attempt to fire again. If the pistol still refuses to fire, try working a few grains of powder into the flash hole or nipple channel and try to fire again. Be prepared for a delayed ignition. Finally, deactivate the firearm, remove the nipple and place the breech end of the barrel in a bucket of water for at least an hour before attempting to pull the ball. Then clean the barrel, dry it completely, load properly and attempt to fire again.

Swab the bore between shots to remove fouling. After the shooting is finished for the day, *clean* the pistol thoroughly before storing it. The same techniques used to clean a rifle may be used with muzzleloading pistols.

## Summary

In this session we studied, loaded, fired and cleaned single-shot muzzleloading pistols. As in the other shooting session we reviewed safe handling of black powder and muzzleloading arms, shooting safety and safety precautions associated with the type of arm being used. The uses of black powder pistols were also reviewed, noting that they are not recommended for hunting big game but are useful in target shooting, recreational shooting, re-enactments of the appropriate period and occasionally as small game hunting tools.

## Summary Activities

1. Have shooters fire and clean a muzzleloading pistol.
2. Discuss the uses of these types of firearms and the reasons they might not be used for other purposes.
3. Hold a fun shoot using muzzleloading handguns.
4. Have a re-enactment, buck skinning or other historical group perform or discuss what they do and why they do it.

## **Exhibit and Sharing Ideas**

1. Demonstrate the loading and/or cleaning process for either a muzzleloading pistol or a cap-and-ball revolver.
2. Research the history of handguns and share your findings with your club or another interested person.
3. Share what you have learned in this lesson with another person interested in muzzleloading.
4. Write what you have learned in your shooting journal and exhibit the journal in an appropriate activity or event.
5. Give an illustrated talk about the use of muzzleloading handguns.

# Loading a Cap and Ball Revolver

*The following pages are meant to display, with historical accuracy, the steps involved in loading a percussion-style revolver. 4-H members interested in firing percussion guns must do so under the guidance of a 4-H certified black powder instructor.*

Before the advent of self-contained metallic cartridge ammunition, loading a revolver was an involved process. Each of the following steps required consistency and precision in order to maintain accuracy when loading loose components. Individuals interested in a speedy reload could load extra cylinders and carry them in a

pouch on their belt where they were within easy reach. When the need arose, a shooter could quickly replace a spent cylinder with a fully loaded one. Paper cartridges of the period featured a pre-measured powder charge and a projectile wrapped inside. This also sped up the loading process.

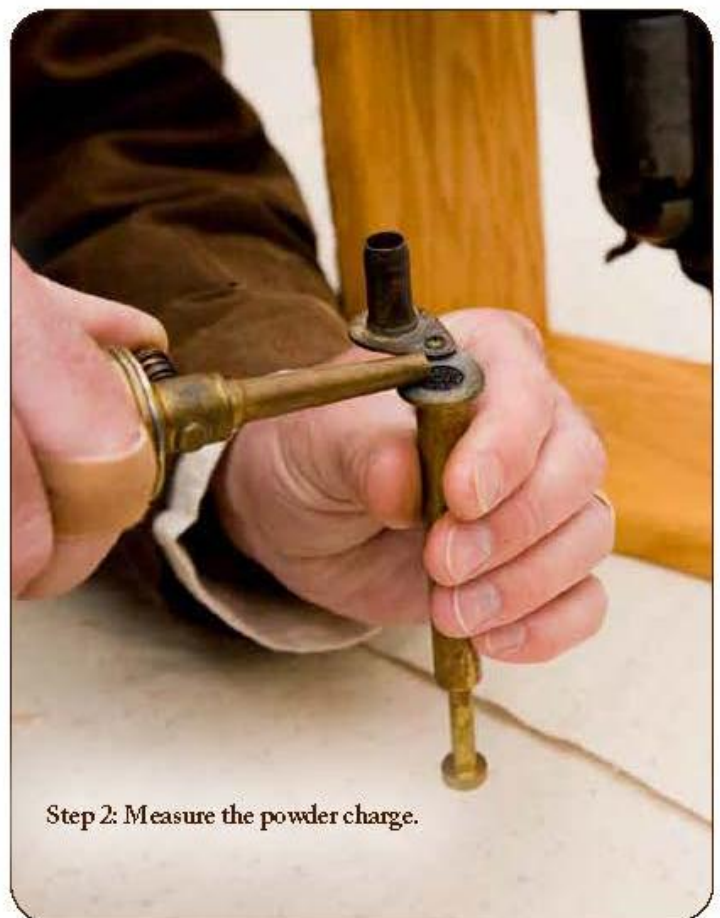
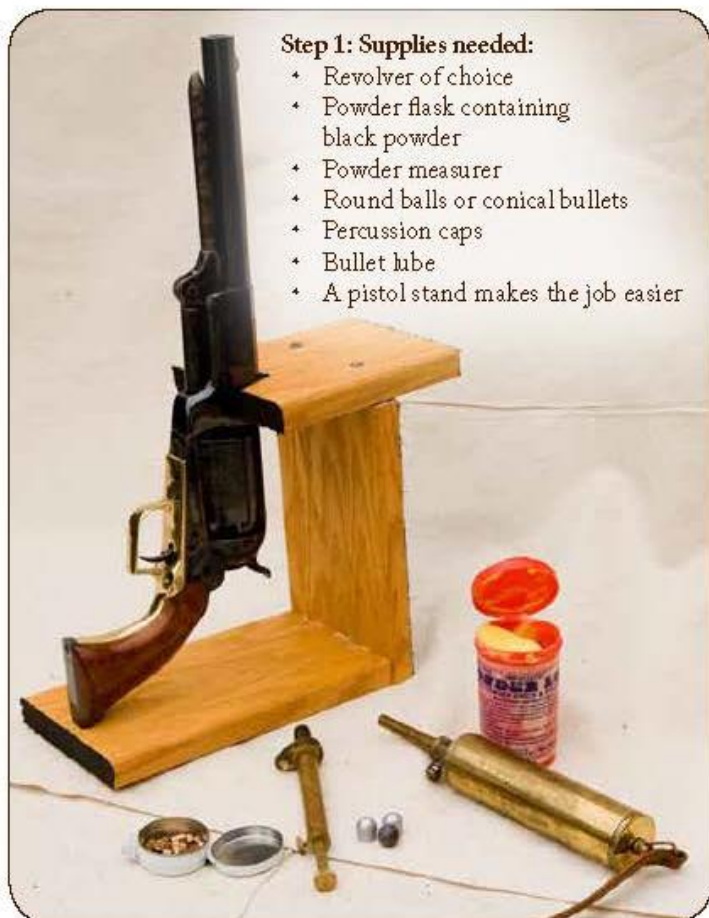



Step 3: Charge the chamber.

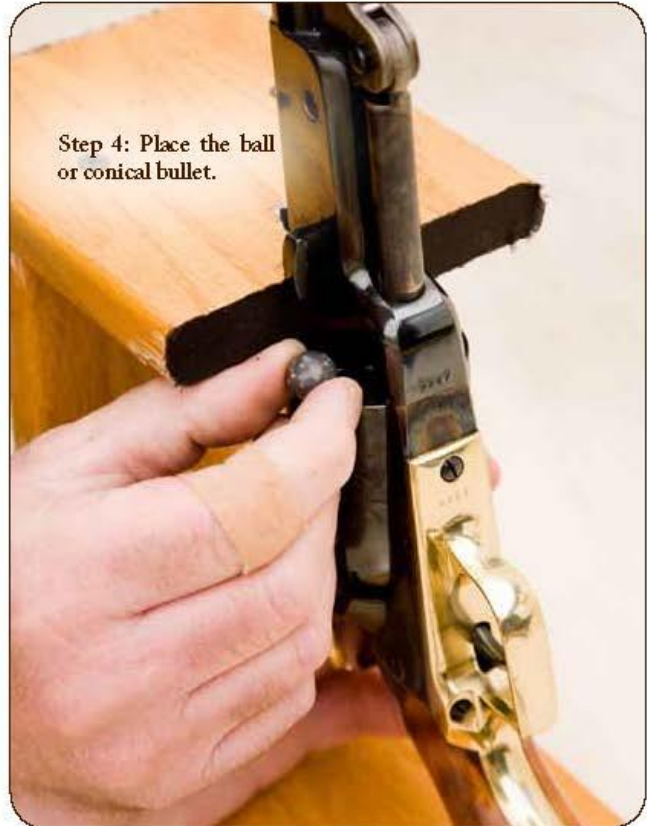

Step 4: Place the ball or conical bullet.

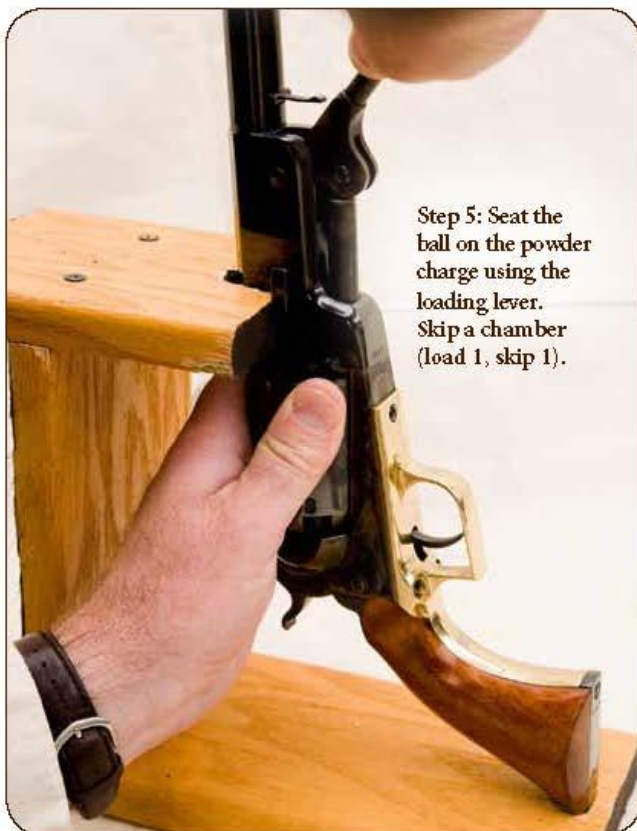

Step 5: Seat the ball on the powder charge using the loading lever. Skip a chamber (load 1, skip 1).

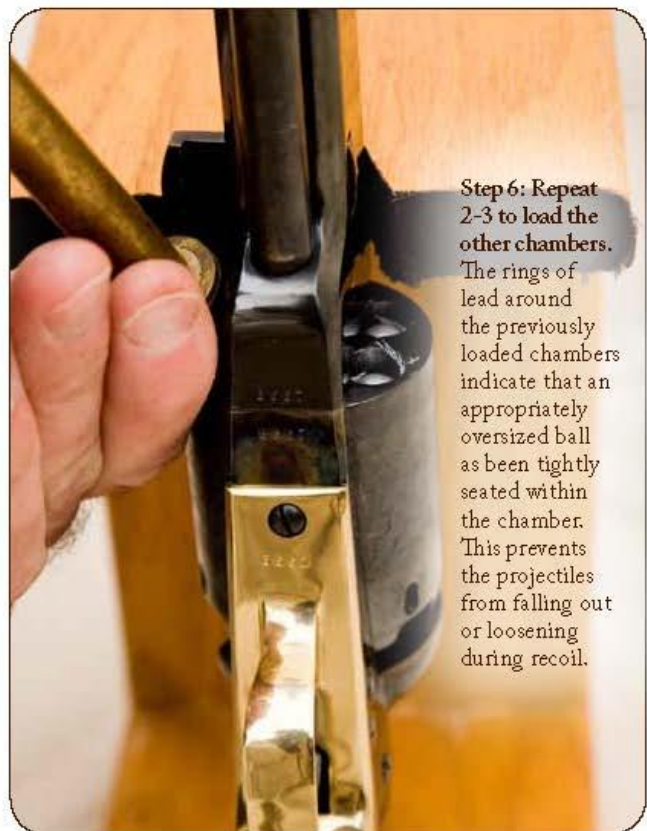

Step 6: Repeat 2-3 to load the other chambers. The rings of lead around the previously loaded chambers indicate that an appropriately oversized ball as been tightly seated within the chamber. This prevents the projectiles from falling out or loosening during recoil.



**Step 7: Apply bullet lube.** This lubricates the barrel, softens black powder fouling, and assists in the prevention of more than one chamber firing at once.

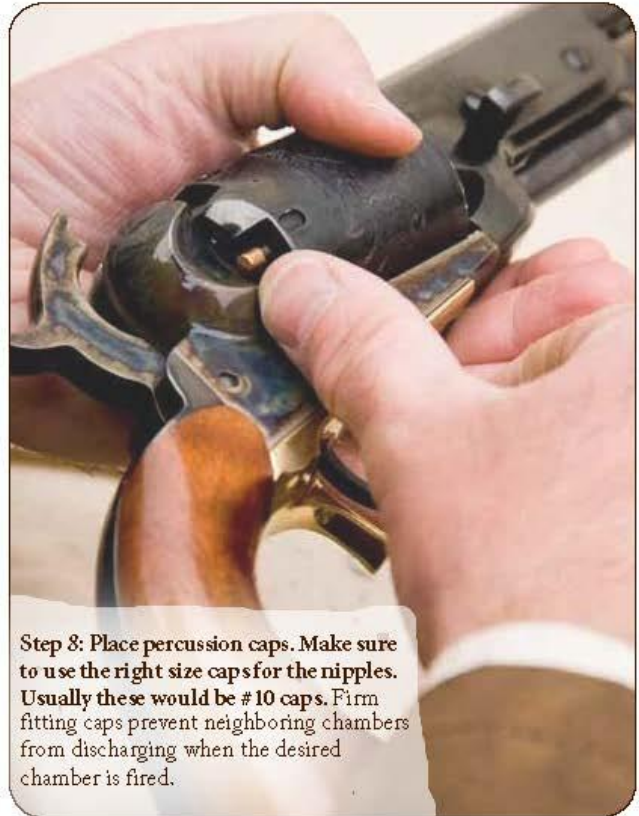

**Step 8: Place percussion caps.** Make sure to use the right size caps for the nipples. Usually these would be #10 caps. Firm fitting caps prevent neighboring chambers from discharging when the desired chamber is fired.



**Step 9: Safety knobs.** Some cap and ball revolvers have safety knobs between the chambers that fit into a notch in the hammer. Placing the hammer over the knob prevents the cylinder from rotation in the holster and discharging accidentally. This reproduction 1847 Walker by Colt features the original arrangement of one safety knob. Other models had safety knobs between each chamber. This safety mechanism is better than nothing, but wise shooters load five rounds and rest the hammer on the empty chamber.

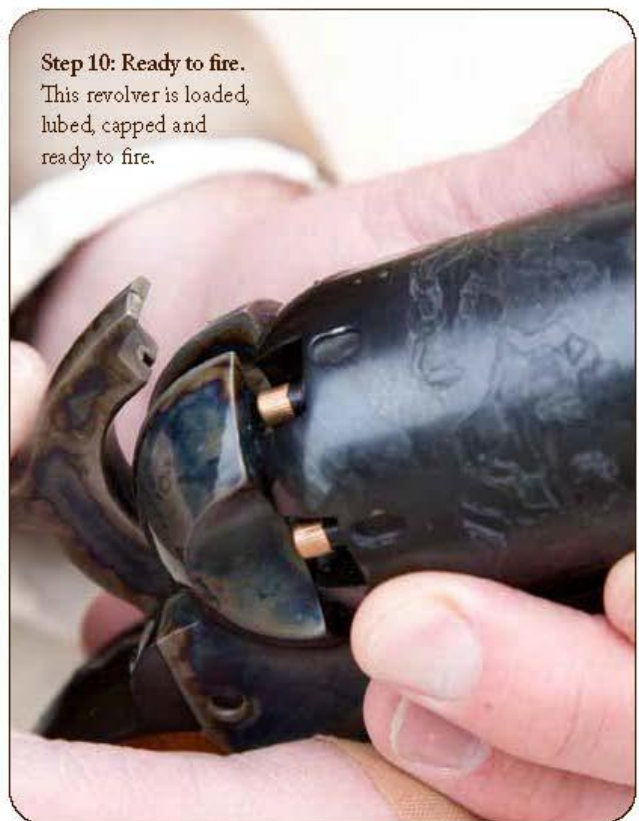

**Step 10: Ready to fire.** This revolver is loaded, lubed, capped and ready to fire.



**Have a little fun.**  
As the smoke would indicate,  
it is easy to identify a shooter  
using black powder.

While loading a 6-shot cap and ball revolver may seem slow and tedious, repeating firearms were a great improvement over loading after every shot. At the bottom left of the page is a replica flintlock pistol from the Historic Old Fort Benton Museum in Fort Benton, Montana, that represents a time when a loaded

gun meant one shot after which the tomahawk became a final means of self-defense. The bottom right is an 1830s or '40s original double barreled muzzle loading pistol, courtesy of the Museum of the Upper Missouri in Fort Benton, Montana, which provided a second shot before reloading was required.



*Will Abbot photo*



*Will Abbot photo*

## Determining Eye Dominance

Ronald A Howard Jr. and James V. Peter, Jr. \*

---

### Eye Dominance

Most people have a dominant eye, just as they have a dominant hand or foot. When a person looks at an object with both eyes, the dominant eye aligns directly with the object unless an obstruction interferes with a clear line of sight. Under normal conditions, when a finger is pointed at an object, or two or more objects are aligned visually, the dominant eye determines the alignment. Just as some people are truly ambidextrous, a very small number of people have indeterminate eye dominance. The majority, however, have a dominant eye. In most cases eye dominance and hand dominance are on the same side, but many people are cross-dominant. That is, their handedness and eye dominance are on opposite sides.

Humans have binocular vision – they get slightly different images from each eye and blend them in the brain to yield one image and a sense of depth or distance. With both eyes, open, you have a wider field of vision with more peripheral vision and better motion detection. In short, you simply see better when both eyes are

used. Experience shows that shooting skills are learned more easily and often better developed when a shooter learns from the dominant eye side. Where eye dominance and handedness are on the same side, new shooters easily use the dominant side. Cross-dominant shooters have a greater challenge, but they do better when they learn to shoot with the dominant eye.

Some shooters, particularly those with successful experience in shooting with the non-dominant eye, are reluctant to switch. The switching process usually involves a brief period of reduced success and frustration, followed by improved skill levels beyond their original level. Some experienced shooters have learned to shoot one-eyed, closing the dominant eye or obstructing it with a shield, blinder, spot of tape of a small object on the lens of the shooting glasses. Others have learned to override their dominant eye through practiced concentration or to compensate in some other fashion. Fewer than 1 percent of all shooters must shoot one-eyed because of dominance switching. In most cases, the shooter learns to use both eyes and

shoot from the dominant-eye side. Learning one-eyed or with the dominant eye obstructed or closed increases stress and fatigue and reduces concentration and quickness. Results indicate reduced performance levels, increased frustration for the shooter and slower learning.

Learning to shoot well is a challenge. You need every advantage to meet that challenge effectively. Learning from the dominant-eye side is a major advantage.

### How to Determine Eye Dominance

Four basic methods for determining eye dominance is described. Those that provide a check for “cheating” are more effective in an instructional setting. Regardless of the method selected, the exercise should be repeated several times. Instructors should remain alert for eye-dominance related problems with shooting performance.

#### *Coach-pupil Method*

Shooters should get into their coach-pupil pairs, standing several arm-lengths apart and facing each other squarely. The “pupil” should place one thumb over the other, then cross the fingers of the top hand over those of

the bottom one. This leaves a small, triangular opening. Raise the hands, keeping both eyes open, and center the “coach’s” nose in the triangular opening. At this point the coach should note which eye is visible in the opening. Then the “pupil” should bring his or her hands slowly back to the face, keeping the “coach’s” nose in the opening. The hands should come to the dominant eye. Coaches must watch closely for wavering between the eyes, an indication of “cheating” or forcing the hands to a predetermined eye. The exercise should be repeated several times to confirm original results with both partners checking their eye dominance.

*Option:* Shooters could cup their hands together, leaving small openings between the bases of the little fingers and the thumbs. A card or a sheet of notebook paper with a small hole centered in it could also be used.

*Distant-object Method*  
Use any of the methods of making an aiming device outlined above. Center a distant object in the opening. Make sure both eyes stay open and face the object squarely.

*Finger-point Method*  
With a pointing method, a distant object or a partner is used. The finger is pointed naturally at the object with

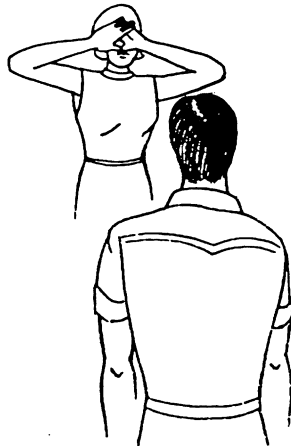

both eyes open and the face square to the object. The eyes are covered or closed alternately. When the dominant eye is closed, or covered, the finger appears to jump away from the original location.

#### *Tube Methods*

Kaleidoscopes, toilet paper tubes and similar objects can be used with many young people to determine eye dominance. When the person is not aware of being tested for eye dominance, the tube will almost always be brought to the dominant eye. This also occurs with spotting scopes, telescopes, and similar tools where one-eyed viewing is needed.

#### **Troubleshooting for Coaches and Instructors**

Some shooters will bring the opening back to their own noses because they are looking at the paper or their hands rather than at the target. Those who use the finger-point method will see

two fingers if they focus on their hand rather than on the target. If inconclusive results are obtained, try another method. Make note of that shooter, however, and watch for evidence of switching dominance in the act of shooting. Consistently missing to one side of the target usually indicates an eye-dominance related problem.

#### **A Note of Caution**

Vision problems can have a serious impact on shooting ability. Often, they go undetected by the shooter or those around them. Unless you are an ophthalmologist or optometrist, avoid “diagnosing” vision problems, but be aware of the types of problems a shooter with vision problems may face. Discuss any potential problems you observe with the shooter and his or her parents. Like teachers who notice reading problems or other vision related difficulties, the shooting instructor may notice things that even the shooter misses. Finally, be sure that all shooters are wearing adequate eye protection while they are on or near the firing line. Some people recommend the use of shooting glasses even for archers. Eyes are precious, and vision is vital to shooting. Let’s do our part in protecting them.

# DOMINANT EYE

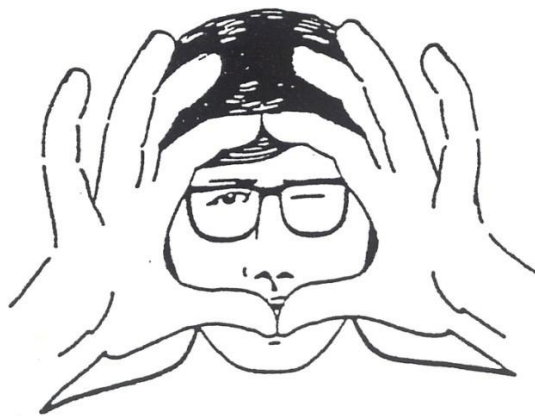
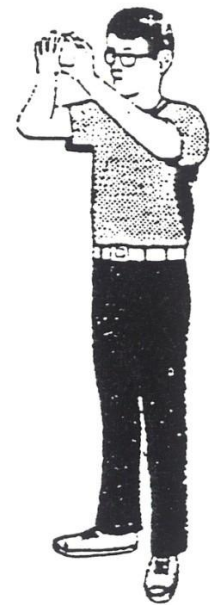
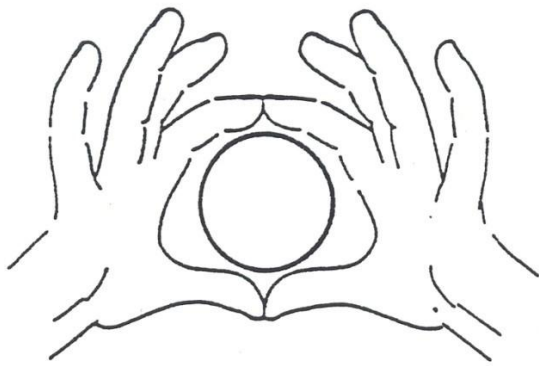

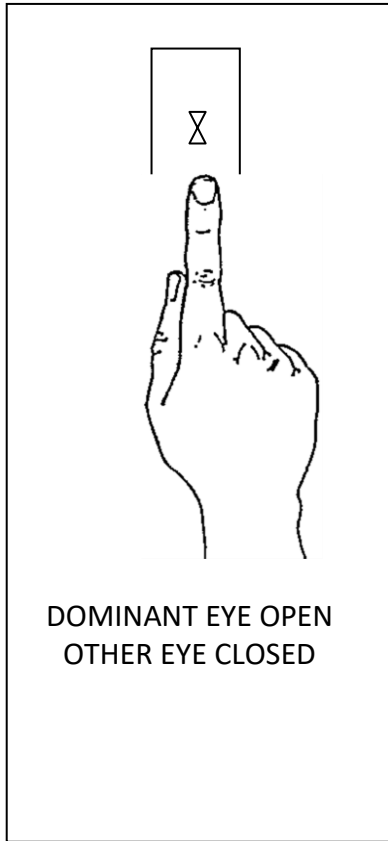

### Check for Eye Dominance

With both eyes open, point your finger at a small object 10 - 20 feet from you.

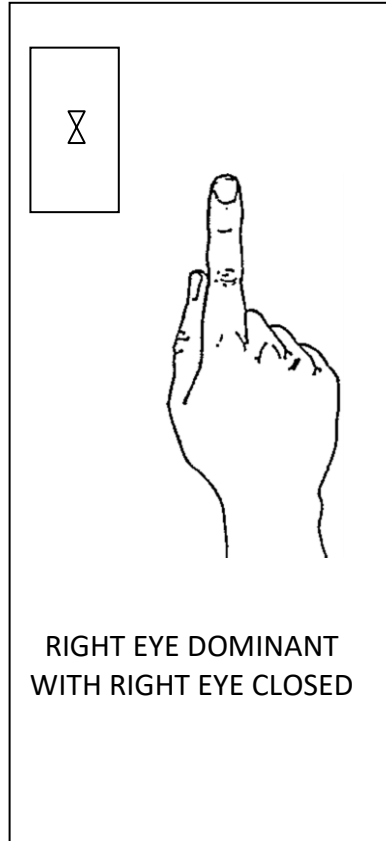

### Right Eye Dominance

Close your left eye and the object will not move.

Close your right eye and the object will appear to jump to the left of your finger.

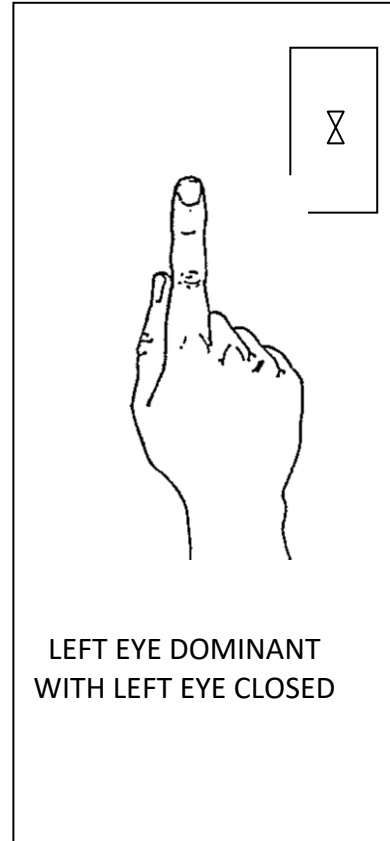

### Left Eye Dominance

Close your right eye and the object will not move.

Close your left eye and the object will appear to jump to the right of your finger.



Figure A-1: Two fingers of left hand simulate rear sight. Index finger of right hand simulates front sight. Represents perfect sight alignment.

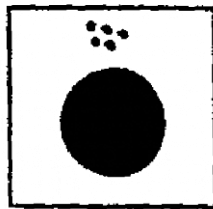

Figure A-2: Keeping tight hand stationary, move left hand down to simulate moving rear sight down.

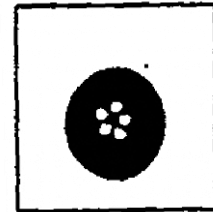

Figure A-3: After the rear sight (left hand) is moved down, realign sights. Thus, right hand moves down to simulate moving muzzle down.

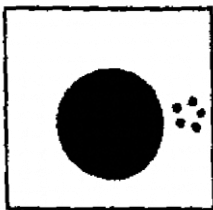
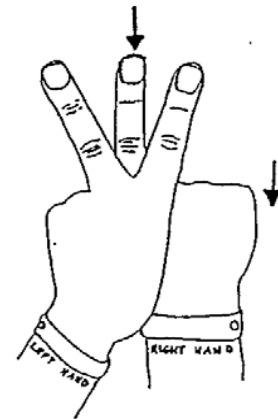
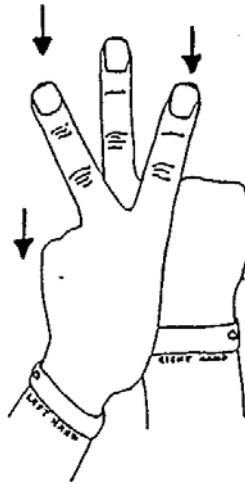

Figure B-1: Two fingers of left hand simulate rear sight. Index finger of right hand simulates front sight. Represents perfect sight alignment

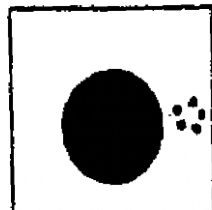

Figure B-2: Keeping right hand stationary, move left hand to the left to simulate moving rear sight to the left.

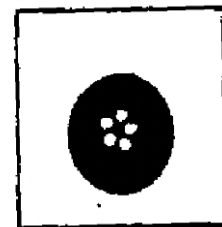
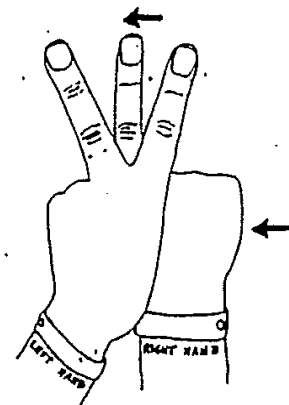
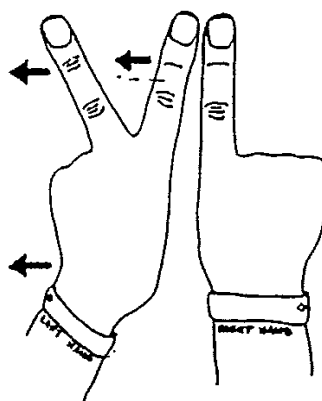

Figure B-3: After the rear sight, left hand) is moved left, realign sights. Thus, right hand moves left to simulate moving muzzle left.



# Non-threatening Hands-on Instruction

James V. Peter, Jr.\*

---

A major element of shooting is stance. When working with shooters, particularly beginners, instructors frequently must use their hands to position them or correct their form or assisting them with equipment and shooting clothing. Even though close contact with the shooter is essential for effective instruction, the instructor must be careful to avoid any action that could appear improper or cause the student anxiety. A few simple actions can ensure a working relationship between instructor or coach and student without any question of anxiety or impropriety.

Respectful, non-threatening treatment of shooters begins with demonstration. Use a junior leader or an assistant to demonstrate proper posture or position and then as to how instructors will handle/assist shooters to correct their posture or position. By telling the shooter what you are about to do you can further reduce his or her anxiety. Ask permission before touching and tell the shooter you are going to push his or her torso forward, raise an

elbow or reposition a hand. The posture of your hands when contacting the student can also ease anxiety. Except in an unsafe situation where immediate and decisive action is required, it is seldom necessary to “grab” a student or the firearm. When your hands are held relatively rigid with the fingers straight and the thumbs resting on the top of the hands, they are much less threatened. Pressure from the palms of flattened hands (fingers not curled) can accomplish most positioning and controlling needs. This is called “Non-threatening Hands On Instruction.”

## Non-Threatening Hands On Instruction

- Positioning or Stance
- Equipment & Shooting Clothing
- Always Respectful
- Use Demonstrations
- Request Permission to touch
- In response to students need
- Avoid Breasts, Buttocks, and Groin

- Should Be Open & Not Secretive
- Governed by Age
- Always Appropriate When Safety of the Individual or Group is At Stake

## Examples and Advice

Assisting with coats, shooting vests or shooting coat or jacket. There are a number of adjustments that can be made on a shooting jacket/coat that help the fit and performance of the individual. As we teach in instructor training there are appropriate methods and inappropriate ways of non-threatening hands on instruction or assistance. Utilizing same gender assistance or students helping students may be the most appropriate for the situation. Age of participants, gender, and individual permissions are also factors that must be considered. The one exclusion is when the immediate safety of the individual or others is at stake.

# Trajectory and Trajectory Experiments

Ronald A. Howard Jr. \*

Many people think that bullets, shot or arrows travel in straight lines just like light. It does not take much shooting experience to realize that projectiles and light behave quite differently. The physics of projectiles (ballistics) is discussed at the end of this fact sheet for those interested. The main purpose of this material is to help you understand how trajectory enters shooting.

Under normal conditions, light travels in straight lines. Changes in the density of substances it passes through may deflect it, but within substances of uniform density (like air) light travels in straight lines.

Electromagnetic forces, like magnets can bend light, but it has no mass (weight).

Projectiles like bullets or arrows have mass. As a result, they respond to gravity under normal conditions. As soon as an arrow leaves the string or a bullet leaves the muzzle, it begins to fall, accelerating toward the earth under the influence of gravity. In fact, if an arrow or bullet was fired parallel to the surface of the earth on level ground, it would hit the earth at the same time as one dropped from the same height at the same time much farther away. In addition to their mass, projectiles are solid objects. Pushing them through a dense medium, like air,

causes friction and turbulence. Both forces affect the projectile immediately. The projectile begins to slow down as soon as it leaves the string or the muzzle.

The slowing influence is cumulative until the projectile finally comes to rest.

These two factors combined cause projectiles to follow a curved flight path. If two straight lines are used to show the line of the bore or the resting position on the string and the line of sight, the line of flight (path of the projectile) would relate to those lines as shown below (Figure 1).

The curved flight path requires that the bore must be pointed above the line of sight to hit a distant object on the line of sight. If the sights are above the bore or the arrow, it must cross the line of sight twice, once while rising and a second time while falling toward the earth. The exact shape of the trajectory curve can be determined by complicated mathematics or by testing. Actual testing yields better results for a given shooter and his or her equipment and is more easily understood

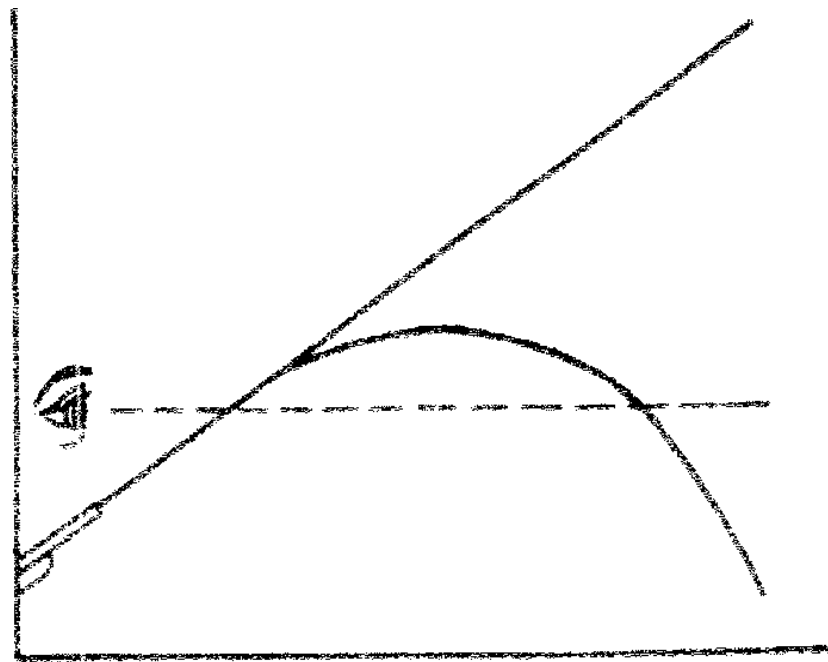

**Figure 1. Relationships among line of sight, line of bore, flight path and drop.**

\* 4-H and Youth Development Specialist, Texas Agricultural Extension Service

The projectile accelerates toward the earth at a rate of about 9.8 meters/second<sup>2</sup> (32 feet per second<sup>2</sup>). If the projectile was fired parallel to the ground, it would drop 4.9 centimeters (0.16 feet) in the first 0.1 second, 19.6 centimeters (0.64 feet) in 0.2 second, 122.5 centimeters (4 feet) in 0.5 second, and 490 centimeters (16 feet) in 1 second (Table 1). In 3 seconds it would have dropped 44.1 meters (144 feet). If a projectile were able to travel at a constant velocity of 60.96 meters/second (200 feet/second), the trajectory would look like the graph in Figure 2.

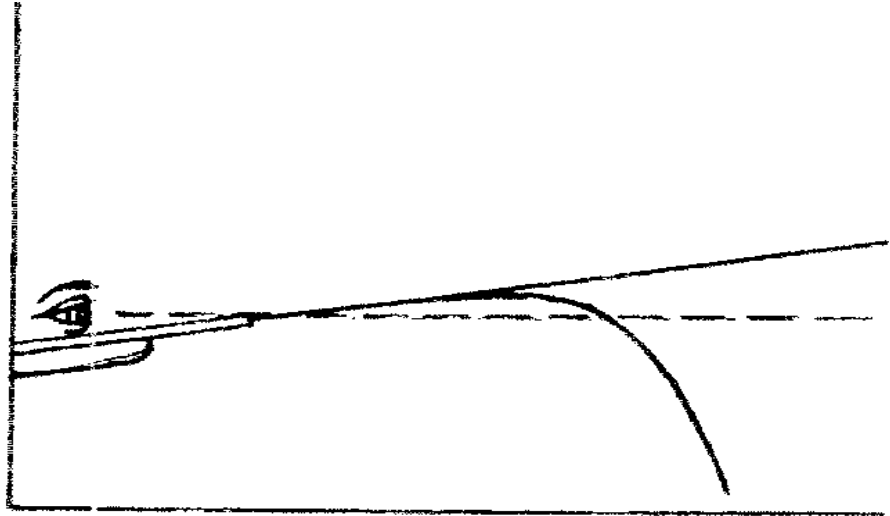

**Figure 2. Trajectory of an idealized projectile traveling at a constant 60.96 meters/second (200 feet/second).**

The actual flight path would curve more sharply downward, since the projectile would be slowing its horizontal motion as gravity pulls it to earth.

You can calculate the trajectory of your personal equipment as you have it set up using the worksheet attached. Shoot the same arrows throughout the experiment if possible. If not, shoot matched arrows with matched fletching. Leave the sight setting the same for all shots and use the same aiming point for each shot and all distances. Measure from the aiming point to the center of the group of arrows and carefully record the distance above (+) or below (-) the point of aim for each distance. Stop shooting if the arrows are falling short (or nearly falling short) of the target. Plot the flight path of the arrows relative to the line of sight. The elevation angle can be calculated if desired by following these steps.

1. Measure the true draw length of the arrow at full draw (the distance from the anchor point to the arrow rest).
2. Measure the height of the sight pin above the arrow rest.

3. Measure the height of the center of the eye above the bottom of the arrow shaft at the anchor point.
4. Subtract the sight pin height from the eye height.
5. Divide that length by the true draw length.
6. The dividend is the natural sine of the angle of elevation from the horizontal.
7. Use a sine table to locate the angle with that sine value.
8. Plot a horizontal line through the eye and sight to the center of the target.
9. Plot a line starting with the distance from the eye to the anchor point below the line of sight at the calculated angle of elevation above horizontal. This is the line of the shaft or the line of the bore.
10. Plot the true line of flight at the distances selected.

This same procedure can be used with rifle bullets, but a longer range is needed and the differences in impact points should be recorded in centimeters or inches rather than meters or feet.

**For Those Who Want to Know More**

Ballistics is the science of projectiles. It focuses on the dynamics of projectile flight and the energy stored and released by the projectile. One of the components of ballistics is the study of trajectory, the flight path of projectiles. In shooting, trajectory related the straight line of sight to a target with the curved flight line of the projectile. The ballistics of bullet or arrow trajectory involves complex concepts in physics and engineering.

Newton's first law, the law of inertia, states that objects tend to remain at rest or to travel in a straight line at a constant speed unless they are acted upon by an outside force. For projectiles, the forces include the energy that accelerates them initially, the acceleration of gravity, friction of the air and drag. Projectile mass, shape and even construction can influence those forces. Complex formulas have been developed to calculate the projectile's ability to retain its energy and velocity (speed)

in a direction). Sectional density and ballistic coefficient are two measures of the “slipperiness” of a projectile.

A projectile starting at rest is accelerated by the stored energy of the limbs, air charge or expanding gases of the fired round. The internal ballistics (those inside the firearm bore or while the arrow is on the rest) limit the motion to horizontal and vertical vectors (components of the total velocity of the projectile). Under most conditions the horizontal velocity is greatest.

External ballistics are more complex, and they begin as soon as the projectile leaves the bore or the bow. The horizontal vector of velocity is measured by its horizontal speed toward the target. The vertical vector is measured by its speed upward, perpendicular to the surface of the earth. Both the horizontal and the vertical vectors of velocity begin to decrease immediately. Friction and turbulence in the air reduce the horizontal velocity. The pull of gravity reduces the vertical velocity. Note that a negative acceleration or velocity in the vertical component means the projectile is moving toward the earth rather than away from it. Wind currents or the rotation of the projectile may cause a lateral movement.

High initial and retained velocities result in a “flatter” trajectory. That is, the arc of the projectile from the shooter to the target is less peaked. The less time the projectile is in flight, the less outside forces influence it. The obvious conclusion is that “faster is better.” However, obtaining optimum ballistic performance involves balancing competing factors rather than simple maximization of any one factor. Limits are imposed by the

chemical structure of the powder, strength of the materials used, mass of the firearm and the strength or recoil resistance of the shooter. Other factors, like barrel life, consistency in energy release, economics, projectile construction and many more reduce the upper limit toward some optimum value.

Changing a single factor of the internal ballistics can result in major changes in external ballistics. Altering the mass of a projectile results in changing its shape. Both sectional density (a measure of the mass divided by the diameter or basal area) and ballistic coefficient (a measure of the bullet’s ability to overcome resistance of the air, which involves sectional density in its calculation) are related to the shape of the bullet. Optimizing mass and initial velocity with performance and terminal velocity involves many factors. The results of changing bullet mass may be surprising. An empirical test could be done using bullets of similar shape and diameter but different weights. Thirty caliber bullets are available in flat-based spitzer shapes in weights from about 110 grains to 200 grains. Interested shooters could fire a test series with bullet weight and compare trajectory curves to determine the optimum bullet weight for that shape in their rifle.

Both momentum and energy are related to the velocity and mass of the projectile. Momentum is the product of the mass and the velocity. Kinetic energy (the energy of moving objects) is the product of the mass and the square of the velocity divided by two.

Projectile use is a major determining factor in balancing momentum and energy. When a projectile comes to rest, the

remaining energy and momentum are translated into penetration and shock. On target ranges bullets and arrows need only enough momentum and striking force to penetrate the target. The shot must have enough remaining energy and momentum to break clay targets. In hunting situations, small game arrows, shot and bullets kill by hydrostatic shock. The energy of the striking bullet displaces water in the tissue, causing immediate disruption of vital functions. Momentum is not critical, but kinetic energy is. Big game arrows kill by penetration and hemorrhage. Very little hydrostatic shock is produced, so momentum is much more important than kinetic energy. Big game bullets must combine shock with adequate penetration to reach vital areas. Considering the use of the projectile adds complexity to making ballistic decisions. This may explain the large array of arms and ammunition available today.

Many ballistic experiments can be tried by shooting sports participants. Most would be worthy of entry in science fair competitions under the categories of physics and engineering. Altering one factor at a time, such as sectional density or velocity, may offer easier explanations of the events taking place. For the shooter more interested in performance on targets or game, the arms and ammunition companies have tables that can assist in selecting the appropriate combinations of factors to do the job at hand. Wise shooters will test the listed values for themselves using their own firearms, particularly where the shape of a trajectory curve is concerned. Their observed data is much more valuable than the theoretical data from the tables.

**Table 1. Theoretical values for drop from the acceleration of gravity and distance traveled for idealized projectiles fired parallel to the surface of the earth at a constant velocity of 60.96 meters/second (200 feet/second) and 914 meters/second (3000 feet/second) is given below. The lower velocity corresponds to a very fast arrow. The higher velocity approximates a high velocity center-fire rifle cartridge.**

| <b>Time</b> | <b>Distance Dropped</b> |             | <b>Distance Traveled<br/>@200ft.sec</b> |            | <b>Distance Traveled<br/>@3000ft.sec</b> |            |
|-------------|-------------------------|-------------|---|------------|--|------------|
|             | <b>(sec)</b>            | <b>(cm)</b> | <b>(ft)</b>                             | <b>(m)</b> | <b>(ft)</b>                              | <b>(m)</b> |
| 0.1         | 4.7                     | 0.16        | 6.1                                     | 20         | 91.4                                     | 300        |
| 0.5         | 19.6                    | 0.64        | 12.2                                    | 40         | 182.8                                    | 600        |
| 0.3         | 44.1                    | 1.44        | 18.3                                    | 60         | 271.2                                    | 900        |
| 0.4         | 78.4                    | 2.56        | 24.4                                    | 80         | 365.6                                    | 1200       |
| 0.5         | 122.5                   | 4.00        | 30.5                                    | 100        | 457.0                                    | 1500       |
| 0.6         | 176.4                   | 5.76        | 36.6                                    | 120        | 584.4                                    | 1800       |
| 0.7         | 240.1                   | 7.84        | 42.7                                    | 140        | 693.0                                    | 2100       |
| 0.8         | 313.6                   | 10.24       | 48.8                                    | 160        | 731.0                                    | 2400       |
| 0.9         | 369.9                   | 12.96       | 54.9                                    | 180        | 822.6                                    | 2700       |
| 1.0         | 490                     | 16.00       | 61.0                                    | 200        | 914.0                                    | 3000       |
| 1.25        | 765.6                   | 24.00       | 78.2                                    | 250        | 1142.5                                   | 3750       |
| 1.5         | 1102.5                  | 36.00       | 91.4                                    | 300        | 1371.0                                   | 4500       |
| 1.75        | 1500.6                  | 49.00       | 106.7                                   | 350        | 1599.5                                   | 5250       |
| 2.0         | 1960                    | 64.00       | 121.9                                   | 400        | 1828.0                                   | 6000       |



# Pistol and Rifle Range Commands

William F. Stevens, John Kavsnicka and Ronald A. Howard, Jr.\*

Basic range control procedures are familiar to most rifle or pistol shooters. After shooters become familiar with range operations, behavior and etiquette use the conventional range commands. When new shooters are learning, however, modifications can enhance safety and provide better control. The following procedure is effective, and we recommend it to you. Range commands are in bold type. Coach, shooter or range assistant actions and comments are listed in normal type. Options or temporary parts of the command are indicated by brackets [ ] Parentheses ( ) enclose alternative or additional commands that can be used with beginning shooters. Refer to Fact Sheet 13 for additional information.

## **Shooters (Relay {state number}) to the line.**

Shooter-coach pairs move to the firing line with their rifles or pistols empty, actions open and exposed to view, muzzles pointed in a safe direction and fingers off the trigger. Range staff will also check each rifle or pistol on its way to the range.

## **Is the line ready? Respond by firing point number, please.**

Each shooter or coach will reply with “ready” or “not ready” and state his or her

firing point number. Any firing point not

responding will be queried directly to determine their situation and whether they need assistance. Once the line is ready, the range officer will declare its status.

## **The line is ready. [The range (line) is clear, you may handle your firearms (pistols, rifles).]**

**OR**

## **Pick up your firearm (pistol, rifle). Keep the muzzle down range, the action open, the safety on and the finger off the trigger.**

Shooters pick up rifles or pistols, verify the condition, make any preparations with the empty rifle necessary for the shooting taking place and await further instructions. “Coaches” and range assistants observe muzzle control and maintain control over all ammunition. *See the Fact Sheet 17: Pistol and Rifle Shooting Procedures* for further information.

## **Load your firearm (rifle, pistol).**

### **Safeties off.**

### **Assume a comfortable (proper) firing position.**

Align your sights. (Focus on the front sight and obtain proper sight alignment.)

## **[Raise your pistol (rifle) to firing position. (Keep the front**

**sight in focus and maintain your sight alignment.)]**

## **Obtain a proper sight picture. (Maintain your focus on the front sight and proper sight alignment.)**

### **Fire when ready.**

Squeeze (Press) the trigger. (Maintain your front sight focus, sight alignment and sight picture until the projectile {bullet, ball or pellet} hits the backstop.)

### **Cease fire.**

The cease fire command must be obeyed immediately, even if a shot is nearly ready. It is complex and will need step-by-step reinforcement until it is nearly reflexive.

## **Make your firearm (rifle, pistol) safe. [Keep the muzzle pointed down range.**

## **Open the action and make sure all ammunition is removed from the firearm. Place the safety in the “on” or “safe” position.]**

Ground your firearm (rifle, pistol), leaving the action open and score targets.

Firearms may not be handled until the range has been declared clear once more.

Conventional Range  
Commands

## **Relay [X] (shooters, relay [X] match [Y] to the line.**

\* Conservation Affairs Manager for Federal Cartridge Company, Anoka, MN; Executive Director, Minnesota Deer Hunters Association; and 4-H and Youth Development Specialist, Texas Agricultural Extension Service.

**The preparation period begins now...The preparations period has ended**

This command declares that the range is clear and unloaded firearms may be handled, adjusted or otherwise made ready. They may NOT be loaded.

**Is the line ready?**

Any shooter not ready must indicate he or she is not prepared to begin their relay. If any shooter is not ready, the range officer will announce that **the line is not ready** and repeat the process after a brief pause.

**The line is ready.**

This command indicates that all shooters have completed their preparations and are ready to begin the relay.

**Ready on the right. Ready on the left. Ready on the firing line.**

This command announces that the firing line is active. In some events, the shooter may insert a magazine or load after the “ready on the right” command.

**Commence firing. (Fire when ready, fire at will, the range is hot.)**

Live firing may commence. The first two terms are more commonly used. Their use is

Encouraged to promote consistency.

**Cease firing. [Unload, open the action, ground your firearm.]**

The initial command carries the implication of all the others, but they are used explicitly in some shooting events.

**Change (score or score and paste) targets. (The range is clear, you may change targets.)**

Shooters may proceed down range to replace, retrieve or score targets. Firearms may not be handled until the range has been declared clear once more.

Several additional commands may be used.

**The firing line is clear. You may handle your guns.**

This is equivalent to the “make ready” command.

**Police firing points.**

This command is used when shooters need to pick up their fired brass and other materials around the firing points, often at the end of one or more relays.

**As you were.**

This command rescinds the one immediately preceding it. It returns control to the previous level, for example, if the range officer has announced “the line

is ready,” “as you were” would indicate that it is not ready.

**Carry on.**

This command allows shooters to proceed with the actions taking place before some interruption occurred.

**Make your firearms (pistols, rifles) safe.**

The range officer may include or expand this command. The firearm should be unloaded, magazines removed and actions or cylinders opened and plainly exposed to view. Muzzles must continue to point down range.

**Ground your firearms (rifles, pistols).**

The safe firearm must be placed on the shooting mat, bench or other safe surface. It may not be picked up or handled without specific instruction from the range officer.

Each action is the same as for beginning shooters above. Do not rush to move to the “standard” range commands. The beginning shooter will benefit from the verbal reinforcement of the positive actions they should be taking. Move to the conventional commands after you are completely satisfied that the fundamentals of firing a shot and range safety are instilled in the shooters.

# Rifle and Pistol Shooting Procedures

Ronald A. Howard, Jr., William F. Stevens and John Kvasnicka\*

Beginning shooters must learn a protocol for handling firearms on the line. Instructors or coaches should use an expanded procedure to establish and reinforce safe and responsible firearms handling. Once those processes have become conditioned reflexes, control may revert to the basic range control commands. The protocols outlined here are designed to produce safe and responsible shooters. Numbered items are the basic commands. All items in bold print should be explicitly mentioned during the shooting process for beginning shooters.

**1. Pick up your firearm [rifle, pistol].** Several elements are implicit in this process.

**Keep muzzles in a safe direction.** That means down range while on the firing line and away from people (usually straight up) at all other times. Take time to teach a proper position. Muzzle control is the shooter's personal responsibility with the coach and range personnel reinforcing it constantly and having immediate access to each shooter.

**Check firearms to be sure they are empty.** Verify that each firearm is empty. Control of all ammunition by range assistants or coaches is essential during the early stages of instruction.

**Actions open and exposed to view for visual inspection.** A closed action means "loaded and ready to fire." This, too, is a shooter's responsibility with reinforcement from their coach and all range staff.

**Keep fingers off the trigger until in the act of firing.** Until keeping the finger along the trigger guard becomes a habit, all range staff must watch this carefully.

**Safeties on.** The location and operation of the safety must be thoroughly explained. Define what is meant by "safe" or "on" and "fire" or "off." [Note: Instructors debate the importance of using the safety during range instruction. Many feel it is unnecessary since the firearm is only loaded when a shot is going to be fired. They consider using the safety unnecessary and potentially confusing. Many others feel use of the safety reinforces proper firearms handling and prepares the shooter for field shooting.]

**2. Load [and charge] your firearm.** Safe loading, unloading and charging (air rifles) must be thoroughly demonstrated and explained. Even when coaches will be loading the firearm, reinforce the process step by step early in instruction. Each coach and shooter must be sure the

ammunition provided is appropriate to the firearm being used. When dry firing, **absolutely no live ammunition** should be on the firing line, or in the possession of anyone on the firing line. Ammunition must be distributed through range staff or coaches until shooters can handle their own.

**Place one round in the changer.** If air guns are used, remind shooters that the skirt of the pellet goes to the rear, at least for the first few shooting sessions.

**Close and lock the action.** Reverse this sequence to unload a firearm.

**Charge the arm [rifle, pistol] with air.** To ensure consistent performance, explicit instructions may be needed in the early stages of instruction.

**3. Assume a proper shooting position.** The coach and range staff should assist each shooter into a proper shooting position, oriented and positioned for effectiveness. Each point in the position should be checked to give the shooter advantage. During the early stages of instruction, the position, including foot position orientation to the target, stance, grip and other form elements should be developed gradually and in sequence.

\* 4-H and Youth Development Specialist, Texas Agricultural Extension Service; Conservation Affairs Manager for Federal Cartridge Company, Anoka, MN; and Executive Director, Minnesota Deer Hunters Associations.

**4. Safety off.**

**5. Align your sights.** In the beginning, consider this a two-step process.

**Focus your vision on the front sight.** Align the front and rear sights.

**6. Fire when ready.** The firing process is complex and should be considered in a step-by-step fashion for beginning shooters. Often the first shot is fired “by commands.”

Obtain sight alignment and sight picture.

Squeeze the trigger (press the trigger straight back) while keeping the sights aligned, focusing on the front sight and maintaining your sight picture.

Maintain the sight alignment and sight picture through the shot until the projectile strikes the backstop.

**11. Cease fire.** The cease fire command is also complex and requires step-by-step reinforcement.

**Cease fire. Reinforce immediate response.]**

Make your firearms [pistols, rifles] safe.

Open all actions. Remove all ammunition.

Ground all firearms [rifles, pistols] with the actions open and visible for inspection.

Take one step back from the firing line.

# Analyzing Groups for Form Faults in Pistol Shooting

Ronald A. Howard Jr.\*

---

The NRA instructional manual, *The Basics of Pistol Shooting*, is an excellent teaching tool for pistol instructors. Appendix D lists some common shooting errors and illustrates their impact on group location and pattern and suggestions for correcting errors. It refers to right-handed shooters but states that left-handers will show a mirror image of the illustrated error. Some instructors have trouble in translating the illustrations. The following chart is written in ambidextrous terms as a supplement to Appendix D. Two-handed shooting adds potential for form faults, although they will often mimic those illustrated.

When working with students, instructors should try to sue ambidextrous directions and illustrations when possible. When working with beginning shooters refrain from pointing out errors.

Stress the elements of good shooting form to correct the error. Reinforcing good basic shooting form is a much more effective teaching strategy. It does not clutter the shooter's thoughts with things that must be avoided, but provides a simple set of sound, practiced fundamentals.

Most of the shooting faults and associated group location problems result from difficulties during the follow through. Many involve the shooter anticipating recoil or attempting to control it by grabbing the pistol, pushing it into the recoil, "choking" the grip with excessive pressure or related problems. These problems often result from excessive shooting without adequate breaks, fatigue, shooting big bore pistols with heavy recoil before developing adequate basics, failure to use eye

and ear protection (noise, muzzle flash, or gas blow-back) or poor concentration. Dry firing and ball and dummy exercises are recommended for correcting most of these form faults. Hundreds of dry-fired shots can establish the proper form, making it a habit when live firing is taking place. Air pistols are also excellent tools for correcting form in both pistol and rifle shooters. They are extremely sensitive to form faults and will assist the shooter in correcting many of them. They are noiseless, relatively free of recoil, modest in mass and shoot relatively slow projectiles that demand a strong follow through. They are inexpensive and adaptable to a wide variety of shooting ranges, including boxes stuffed with crumpled newspaper.

\* 4-H and Youth Development Specialist, Texas Agricultural Extension Service.

**Common form faults in pistol shooting and group locations often associated with them.**

| <b>Group Location</b>                    | <b>Form Fault</b>  | <b>Correction</b>  |
|--|--|--|
| No group, shots scattered                | Inconsistent shooting’ basics of sight alignment and trigger control inadequate.   | Review and practice basics; use triangulation and trigger control exercises, return to shooting target backs                 |
| Diagonally low and to the “off” side     | Jerking or snatching the trigger; squeezing with the whole hand during the trigger squeeze                                     | Press with the trigger finger only; dry fire, keeping the sights aligned through the shot; use ball and dummy exercise       |
| Diagonally high and to the “off” side    | Anticipating the recoil and “throwing” the pistol into it’; improper follow through – releasing the trigger finger upon firing | Repeat dry-firing or ball and dummy exercises; concentrate on follow through   |
| Diagonally low and to the shooting side  | Tightening (grabbing) the grip as the pistol is fired; tightening the forearm during the shot                                  | Dry-firing exercise with focus on follow through; use air pistol to reduce recoil anticipation; ball and dummy exercise      |
| Diagonally high to the shooting side     | Anticipating the recoil and pushing with the heel of the shooting hand   | Ball and dummy or dry-firing exercise with focus on follow through   |
| Horizontally strung to the “off” side    | Trigger finger placement wrong, pressed at angle, not straight back  | Experiment with finger placement while dry firing; focus on grip and finger position.  |
| Horizontally strung to the shooting side | Pressing with the thumb during the shot; pushing with the support hand; imbalance between hands using the palm- rest grip      | Dry fire with focus on pressing only with the trigger finger; repeat trigger control exercise; concentrate on follow through |
| Strung low with proper windage           | Pushing the wrist down at the shot, anticipating recoil; trying to control recoil; relaxing the shoulder at the shot           | Dry fire or use ball and dummy exercise; concentrate on follow through; hold position until bullet strikes                   |

# Trigger Squeeze

Ronald A. Howard Jr.\*

---

Proper trigger control involves moving the trigger mechanism to fire a shot without disturbing sight alignment or sight picture. Rifle and pistol shooters commonly refer to this process as “squeezing the trigger.” Although “squeeze” may imply a prolonged pressure rather than a swift movement, it may carry some unintended messages for the shooter. Squeezing a rifle or pistol trigger must be an isolated action. It requires that pressure be exerted straight back on the trigger by the trigger finger alone. Squeezing with the rest of the hand or attempting to force the shot into the desired area by snatching or jerking the trigger is a serious form fault that may be difficult to cure. Using the entire hand or the thumb in the trigger squeezing process can have a serious impact on group size and location. Although it affects both rifle and pistol shooting, its impact on pistol marksmanship is much more evident. The

coach or instructor must be conscious of the potential problem and be prepared to treat it.

Thumbing or squeezing the grips can be diagnosed by reviewing the location of groups on the target. Dry-firing or ball and dummy exercises may reveal the problem more graphically. Practice can cure the tendency to grab, grasp or thumb; but the problem is easier to prevent than to cure.

Be sure to explain what trigger squeeze is and is not to naïve shooters. It may help to use other terms for the process. Many coaches like to use “press” since it conveys the same sense of prolonged pressure but does not imply action by the remainder of the hand. Caution former military shooters to avoid using the analogy of squeezing a lemon or other item with the entire hand. The amount of grip pressure should remain consistent from shot to shot and during the shot.

A simple exercise can help in teaching trigger control. Have each shooter hold their shooting hand in a relaxed manner but in the position, it would assume to hold a pistol. Ask them to practice removing the tip of their trigger finger back toward the wrist without moving the thumb or the other fingers. This exercise helps to develop a smooth trigger squeeze while avoiding extra muscular activity and tiny disturbances in sight alignment and sight picture. It has the advantage of requiring absolutely no equipment.

The more traditional, eye dropper technique is also excellent if thumb movement is carefully avoided during the squeeze. The eye dropper could even be mounted in a pine stock if desired.

\* 4-H and Youth Development Specialist, Texas Agricultural Extension Service.

# Penetration and Shock Demonstrations

Ronald A. Howard Jr.\*

---

This demonstration is an effective way of contrasting the actions of firearms and archery equipment. It requires an adequate range. For best results, use a high velocity cartridge loaded with frangible bullets in the rifle. A bow powerful enough to completely penetrate the backstop material completely should be used. Have junior leaders or parents assist.

First, shoot water filled (completely!) milk jugs, oil cans or similar containers with each arm. The targets should be at the same range from the firing line and close enough to hit them easily. The rifle should produce a response resembling an explosion. The bullet has high

kinetic energy that is quickly transferred to the water as hydrostatic shock. Since water is incompressible, it moves away from the impact area violently. Water in living things behaves similarly, and the bullet kills by tissue disruption and hydrostatic shock.

The arrow should easily penetrate both sides of the jug and may pass through the container without too much disturbance, merely causing a leak or making the jug tip over. It has relatively little kinetic energy and causes very little hydrostatic shock. Arrows are penetrating and cutting projectiles, and they kill large game by massive and rapid hemorrhage.

Repeat the performance on jugs filled with sand, hay bales or some similar backstop. The rifle bullet should be stopped by the material, but the arrow should pass completely through again. This should help the youngster to realize that even a relatively light bow has the ability to drive an arrow through material that is capable of stopping a bullet. Use the graphic demonstration as an introduction to a discussion of safety and the functions of both bullets and arrows in taking game animals.

\* 4-H and Youth Development Specialist, Texas Agricultural Extension Service.

# A Simple Muzzleloading Rifle or Shotgun Loading Stand

Doug Chapman\*

Loading and firing muzzleloading long guns are much safer and easier for beginners when a loading stand is used. The stands shown here may be made from remnants of construction lumber. They can be an excellent exhibit for a muzzleloader shooter, the foundation of a community service project for an experienced group of shooters or wood workers or an individual project to extend the shooting activity further. The stand angles the muzzle down range from the vertical and away from the shooter's face and body. It also forms a stable platform for the rifle or shotgun during the loading process, while supplying a surface to hold the materials and equipment needed for shooting.

## Materials/Equipment

- 2 ft of 2 x 12 stock
- 1 ft 8 in of 2 x 8 stock
- 10 ft of 2 x 4 stock
- 4 ft 8 in of 1 x 2 stock
- 4 5 x 5/16 bolts with washers, lock washers and nuts
- 16d Gold Ardox nails (about 16)
- 8d or 10d finishing nails (about 20)
- carpenter's glue
- saw (table saw or radial arm saw helpful, but not necessary)
- drill (drill press helpful, but not necessary)
- 5/16-in drill bit
- 1-in drill bit
- hammer
- wrench
- brush

\* Indiana 4-H Shooting Sports Committee and 4-H leader, Allen County, Indiana.

## Cutting and Assembly Directions

1. Cut all 2-inch stock to length as outlined below. Take care to keep all edges square and true.
2. Dado or notch and chisel the edges of the 24-inch 2 x 4 pieces to fit the width of the 2 x 12 exactly. Center the dado on the edge of the 2 x 4, leaving equal amounts of material on either side of it. Cut to the inside of any measured lines to get a snug fit.
3. Cut a centered V-notch 1 to 2 inches wide on one long side of the 20-inch 2 x 8 piece.
4. Center a point 4 inches in from one end of the 2 x 12 piece and bore a 1-inch hole to a depth of approximately 1 inch.
5. Dry fit the side supports, placing one approximately 3 inches from the end of the 2 x 12 piece opposite the bored cavity and the other the width of a 2 x 4 support inside it. Mark those locations carefully.

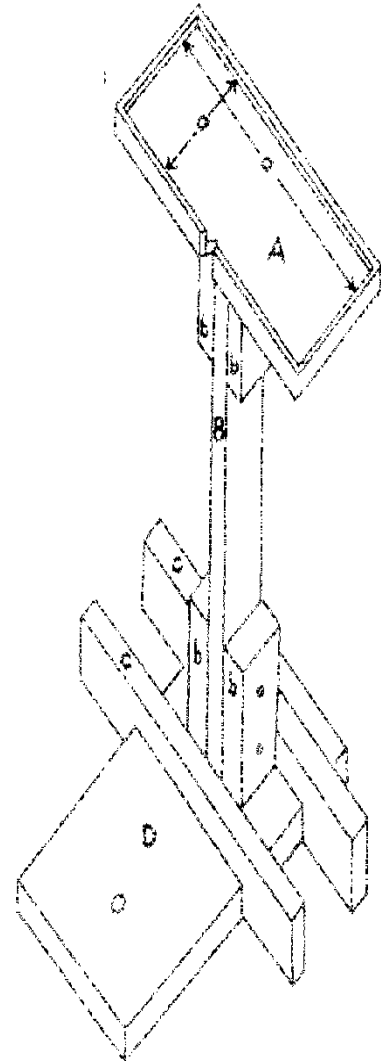

6. Center the leg and leg supports between the side supports and mark their locations carefully.
7. Glue and nail the side supports and leg supports in place from the underside of the base. Nail the leg supports to the side
8. Center the leg and leg supports on the top and mark their locations carefully.
9. Glue and nail the leg supports in place, keeping the edges parallel and the width of the leg apart.
10. Cut the 1 x 2 stock to fit each end of the top. Glue and nail the strips in place leaving a lip on the upper side of the top.
11. Cut a strip of the 1 x 2 stock to overlap the other 1 x 2 pieces on the back edge of the top, making a neat joint with the other materials.
12. Glue and nail the back edging in place.
13. Cut two pieces of 1 x 2 stock to fit the front of the top, keeping the outside edges square and cutting the inside edges at the same angle used in the notch.
14. Glue and nail the front edging in place.
15. Dry assemble the three parts.
16. Bore two centered  $\frac{5}{16}$ -inch holes through the top and bottom leg supports and leg, keeping the bit square.
17. Install bolts in the holes, binding the legs and leg supports in place.
18. The edges may be rounded if desired, and the surfaces may be sanded and finished with a spar varnish or point as desired

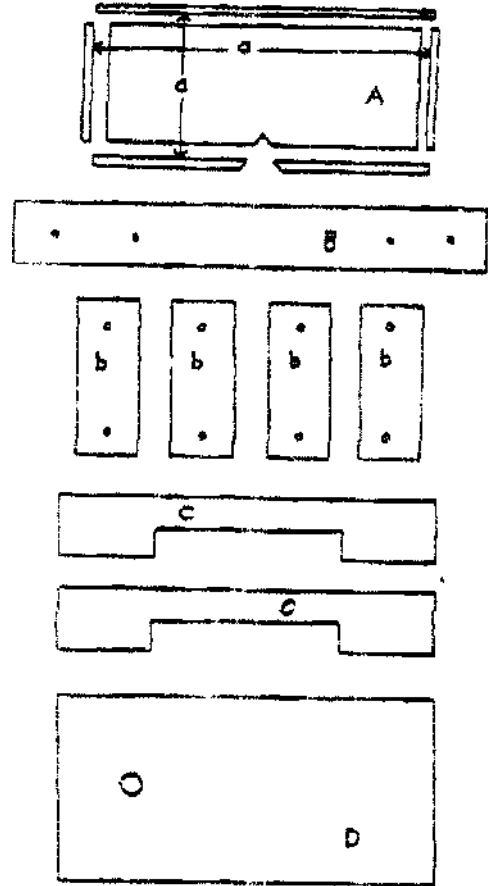

## Bill of Materials

| Part          | Stock  | Length (in)      | # pieces |
|---------------|--------|------------------|----------|
| Base          | 2 x 12 | 24               | 1        |
| Top           | 2 x 8  | 20               | 1        |
| Leg           | 2 x 4  | 30               | 1        |
| Side supports |        | 24               | 2        |
| Leg supports  |        | 10               | 4        |
| Back edging   | 1 x 2  | 21 $\frac{1}{2}$ | 1        |
| Side edging   |        | 7 $\frac{5}{8}$  | 2        |
| Front edging  |        | 9 $\frac{3}{4}$  | 2        |

Muzzle Loading

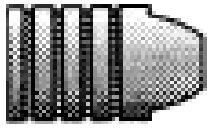

Conical Bullet

or

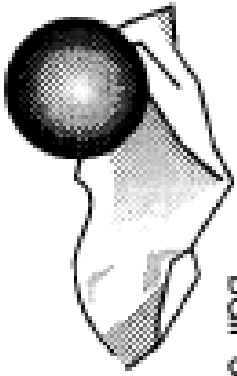

Ball & Patch

and



Powder and Priming Powder

or



Powder and Percussion Cap



© IBCA 1999

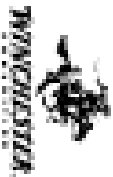

Department of Justice Canada

Ministère de la Justice du Canada

REVISED

3

ISSUE

# Loading a Muzzle Loader

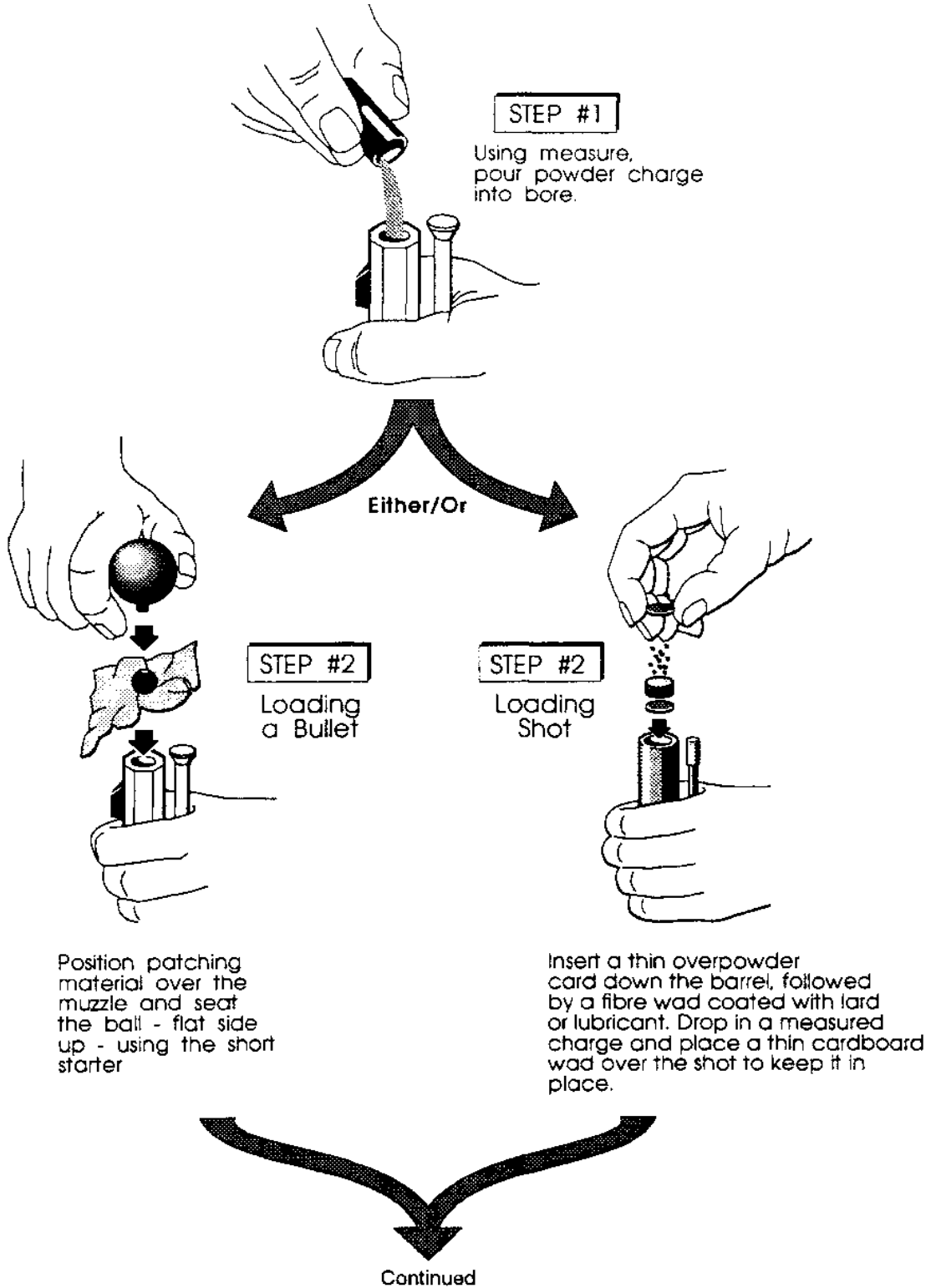

© IHEA 1998



Department of  
Justice Canada

Ministère de la  
Justice du Canada  
09/2014

Continuation

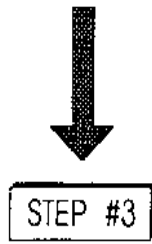

Using long starter and a single blow from the hand, start the ball down the bore.

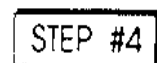
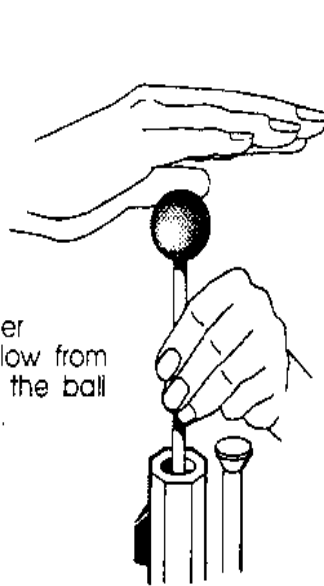

Using the ramrod, and steady pressure, firmly seat the ball against the powder charge. Leave no space.

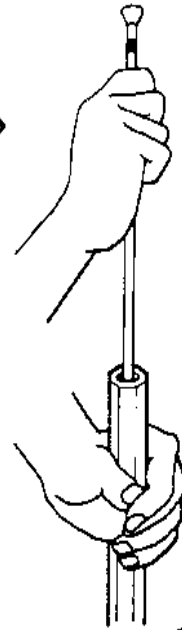

Either/Or

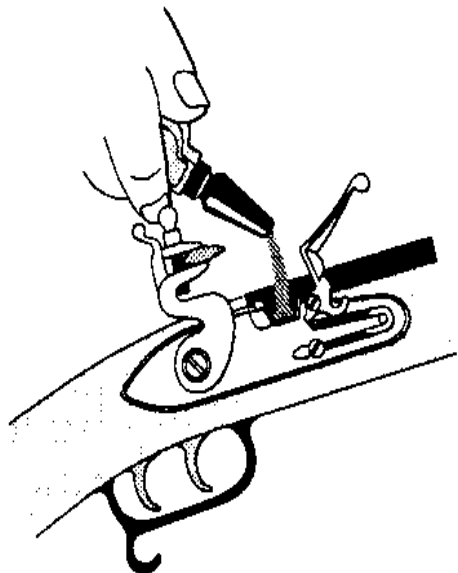
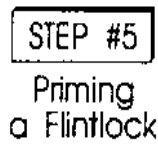

In priming the flintlock, charge the flash pan with FFFFg powder, close, and it is ready to fire.



Priming With a  
Percussion Cap

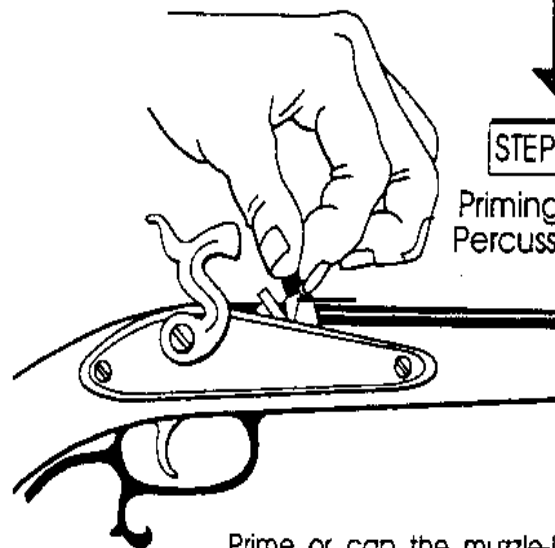

Prime or cap the muzzle-loader and it is ready to fire.

←  → **WARNING**

This is the minimum setting for let-off travel with the trigger set. If you require additional let-off travel, continue turning the screw counter clockwise until you reach the desired engagement. In no event should the engagement be set at less than one full turn counter clockwise from the point of total set trigger disengagement. IMPROPER USE AND/OR IMPROPER ADJUSTMENT OF THE SET TRIGGERS CAN RESULT IN AN ACCIDENTAL DISCHARGE WHICH CAN CAUSE INJURY AND/OR DEATH TO THE SHOOTER OR Bystanders AND DAMAGE TO PROPERTY.

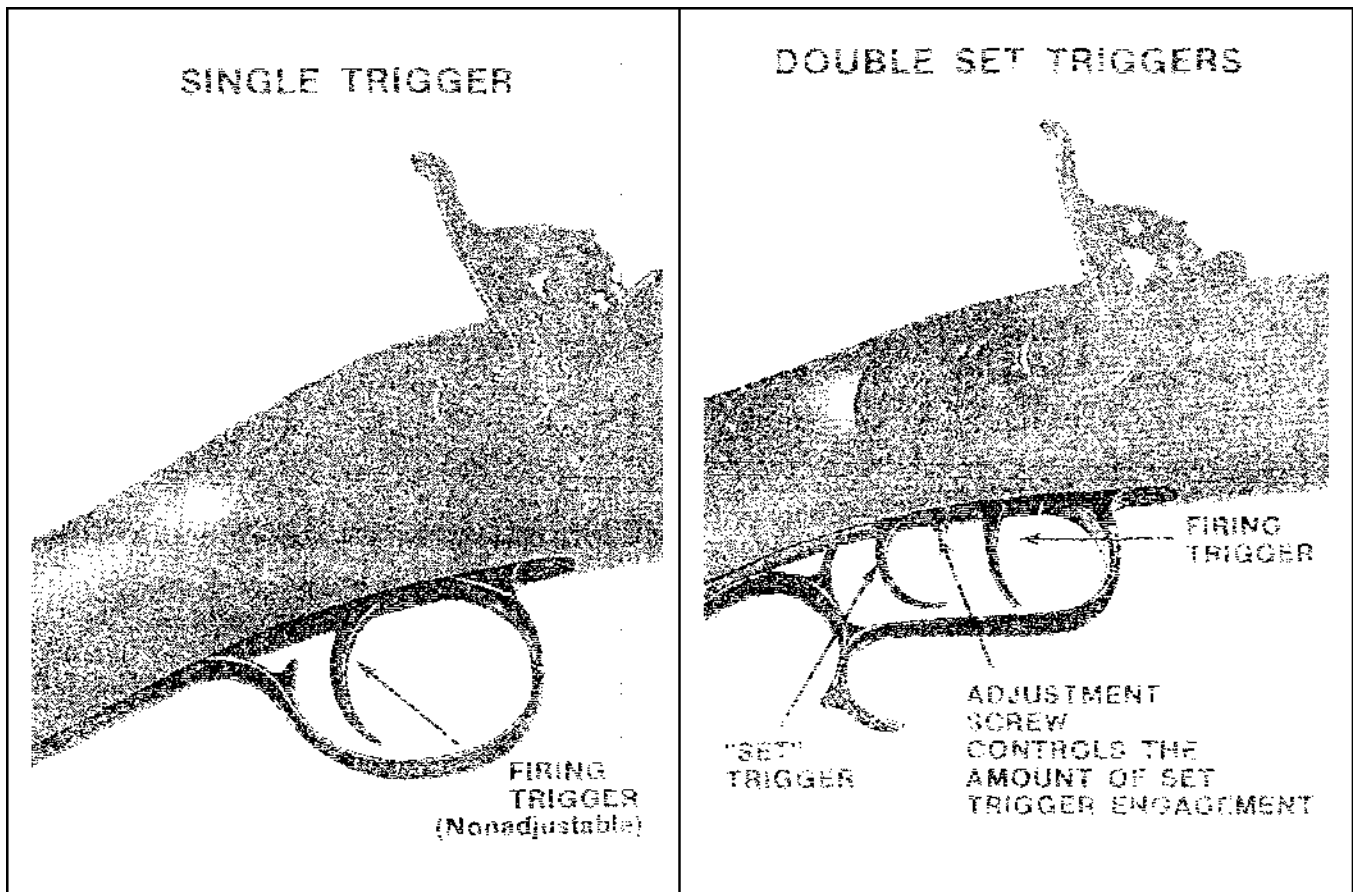

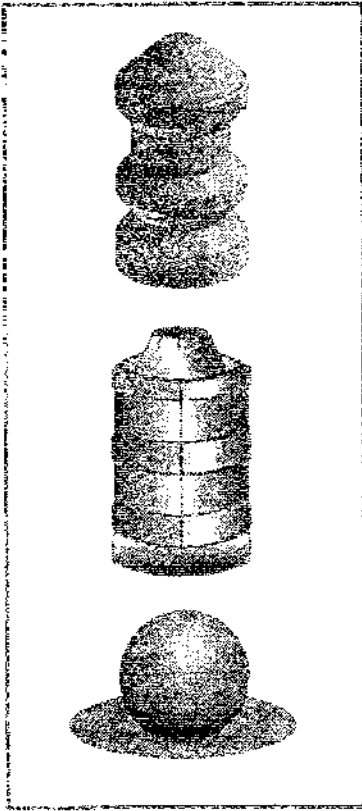

Allows for easy hand-starting of projectiles

## Conventional Barrel

Rifling Starts Here.

Bullet is not fully supported and the potential for misalignment exists, prior to engaging the rifling.



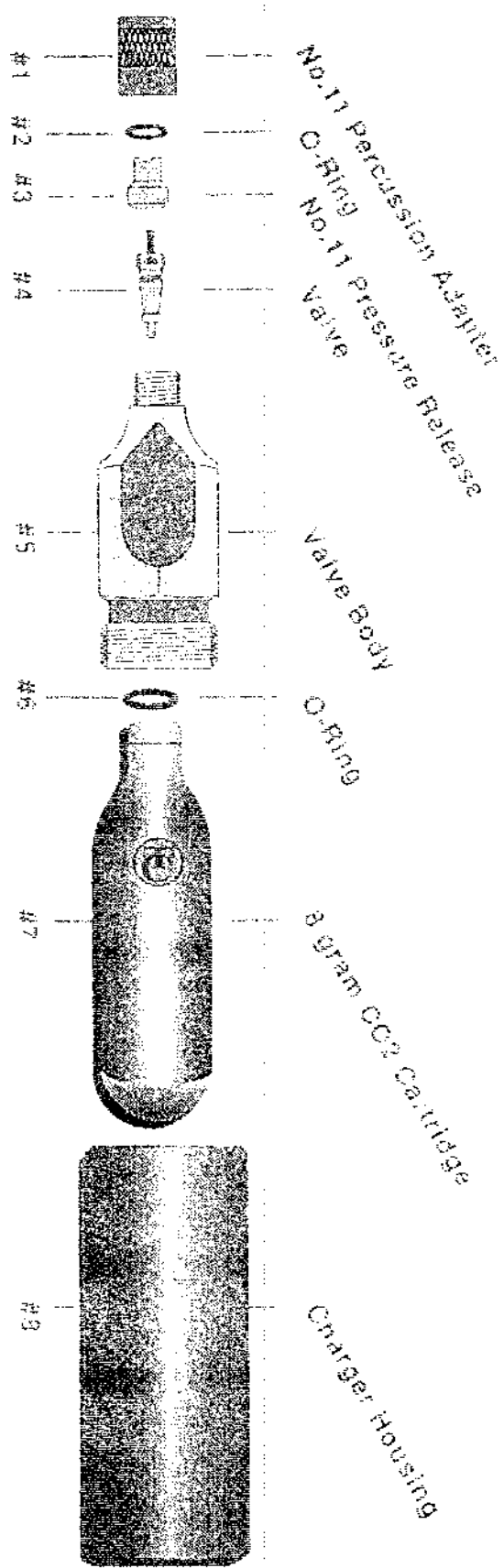

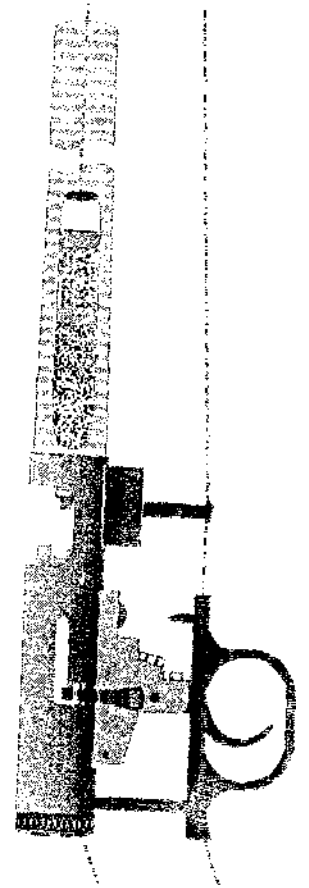
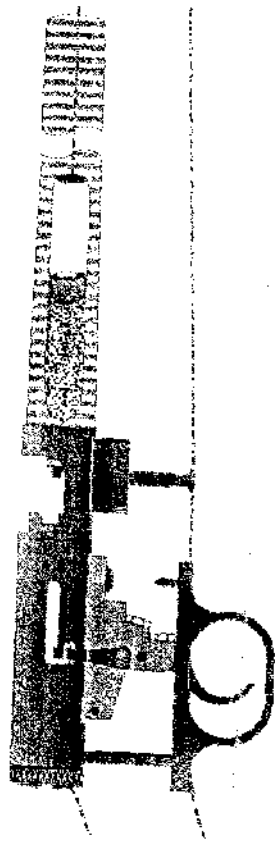
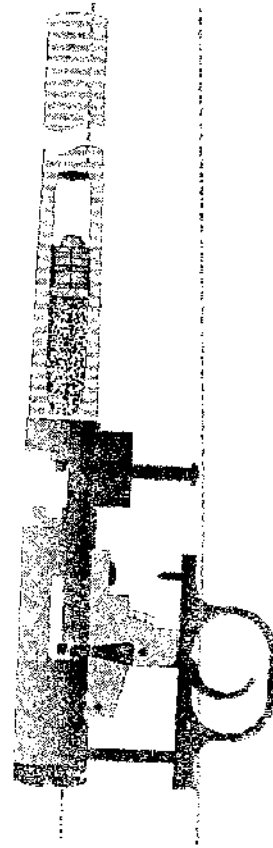
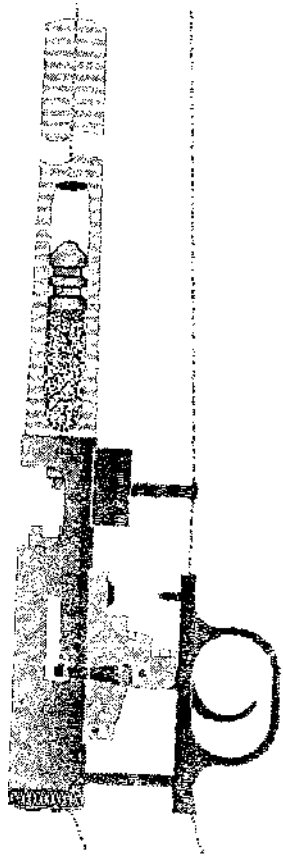

# Types of Black Powder

|         |               |  |
|---------|---------------|--|
| Fg      | Coarsest      | Use in large more muskets of fowling pieces  |
| FFg     | Next coarsest | Use in muzzleloading shotguns, big bore rifles, single-shot pistols of .45 caliber and up. |
| FFFg    | Fast-burning  | Most commonly used – in nearly all cap and ball revolvers.                                 |
| FFFFg   | Finest        | Only used in priming pans of flint-lock.   |
| Pyrodex |               | Only safe substitute for black powder. Check fro legality in your area.                    |

Muzzleloading Fact Sheet 38

## Powder Granulation

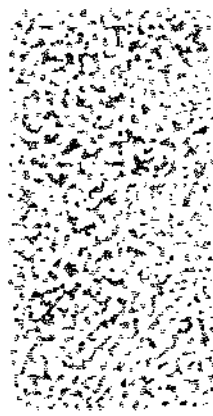

**4F (FFFFg)**

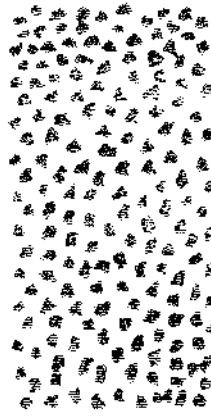

**3F (FFFg)**

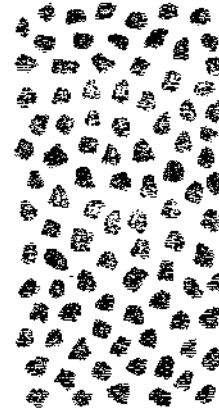

**2F (FFg)**

# Loading Table Diagram

Below is a diagram of a loading table attachment. It is constructed of  $\frac{1}{4}$ " plywood. It attaches to your loading table with two standard C-clamps. The notches provide the necessary support and stability to ease loading in range situations.

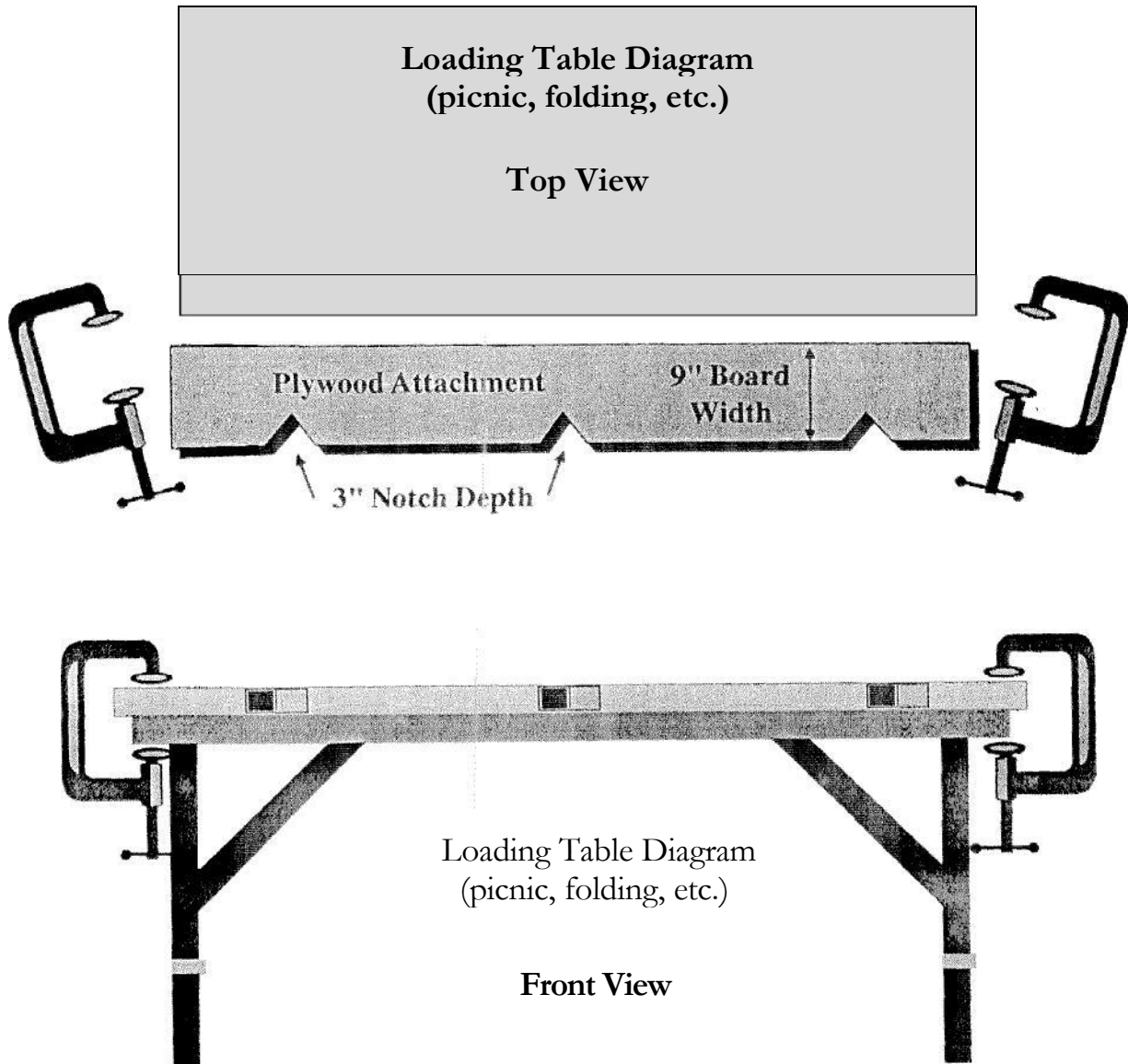

# LOAD EVERY CHARGE WITH CARE

→ **! WARNING** ←  
**IMPROPERLY CHARGING YOUR MUZZLELOADING RIFLE CAN BE DANGEROUS. STUDY THIS CHART CAREFULLY BEFORE PROCEEDING.**

STAY MENTALLY ALERT. THIS TASK REQUIRES YOUR COMPLETE ATTENTION.

BARREL HELD SECURELY WITH MUZZLE UPWARDS - DIRECTED AWAY FROM FACE & BODY

EYES, EARS & ARMS PROTECTED.

USE BLACK POWDER OR PYRODEX ONLY. USE A GRADUATED POWDER MEASURE ONLY AND DO NOT OVERCHARGE. NEVER CHARGE DIRECTLY FROM A POWDER FLASK, CAN OR POWDER HORN.

COMPONENTS & RESERVE POWDER WELL AWAY FROM FIREARM.

**DO NOT SMOKE WHILE LOADING ANY MUZZLELOADER.**

RIFLE UNPRIMED WITH HAMMER ON HALF-COCK. FRIZZEN OPEN ON ALL FLINT LOCK MODELS.

BUTT RESTING FIRMLY ON GROUND SUPPORTED BY SIDE OF FOOT TO PREVENT SLIPPING.

## CHART B



**THOMPSON/ CENTER ARMS**  
ROCHESTER, NEW HAMPSHIRE 03867

## Muzzleloading Live Fire Practical Range Responsibilities

- Everyone on the range is responsible for safety. Anyone who sees an unsafe act can and should call for a “Cease fire.”
- Chief Range Officer – Overall responsibility for everything that happens on the range. Everyone on the range is responsible to the Chief Range Officer.
- Range Officer – Responsible for activities that take place after the learner moves to the loading bench and during firing procedure. Reports to the Chief Range Officer.
- Coach – Responsible for instructing learner, observing (assisting where necessary) correct gun handling procedures and dispensing priming material to learners. Reports to the Range Officer as required or when the line becomes unsafe, as in the case of a misfire.
- Learner – Must follow instructions from coach and demonstrate safe firearms procedures.
- Evaluation Team – Overview total operation and note incidents for discussion at critique following exercise.

## RANGE LAYOUT MUZZLELOADING LIVE FIRE PRACTICAL

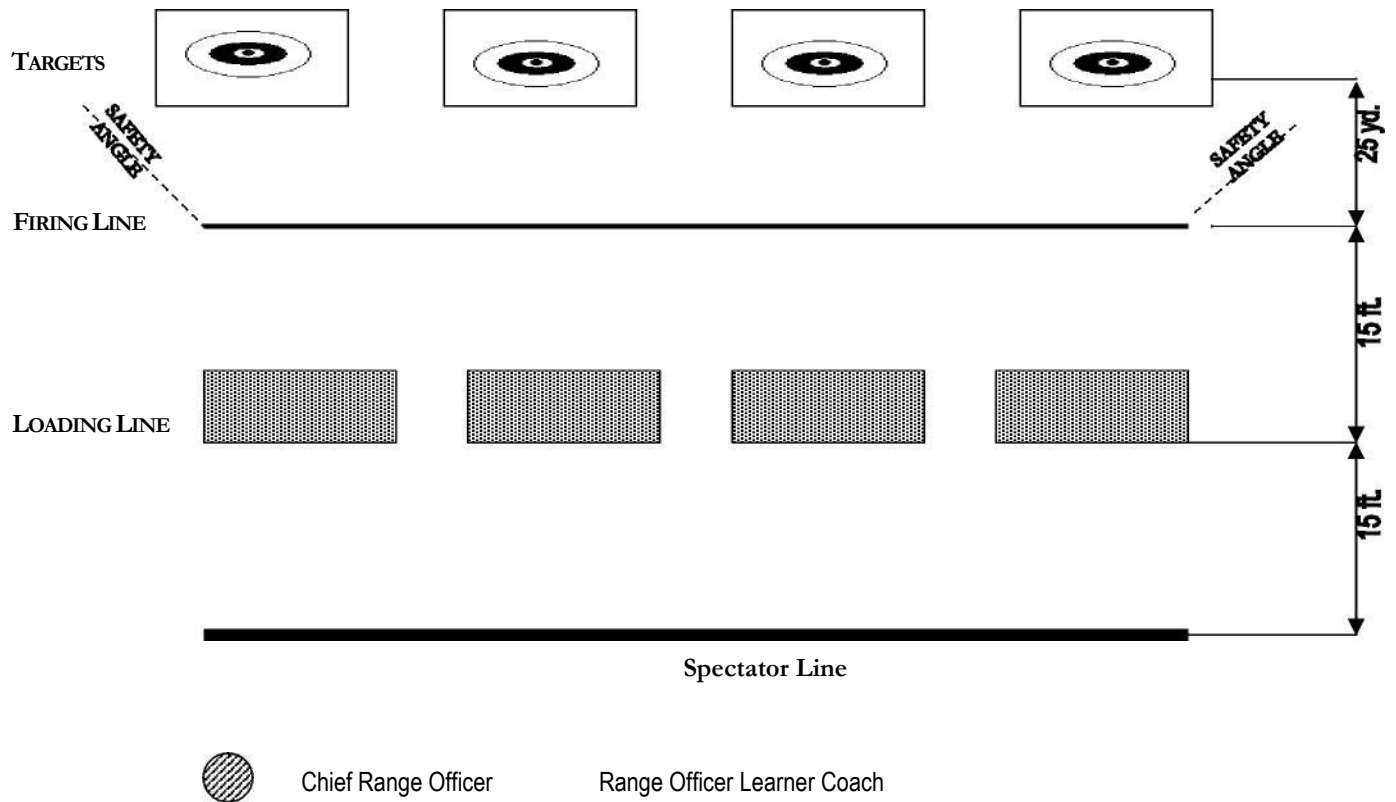

### PHASE I. Briefing

1. Learner/Coach and Range Officer gather at the range Spectator Line where the Chief Range Officer describes the range exercise.
2. Range Officer proceeds to loading station with firearm, equipment and targets, and post the first target(s).
3. Chief Range Officer commands "Learners and Coaches to loading station." Loading Station positions are defined as: a bench located several feet behind the firing line or a bench on the firing line. If the loading benches are at the firing line and there are no baffles between the firing points, loading and firing from all points must be done in unison on command. This also applies to loading from the pouch at the firing line.

The Range is now OPEN, each firing point is to be a mini simulated range for training purposes.

## RANGE LAYOUT MUZZLELOADING LIVE FIRE PRACTICAL

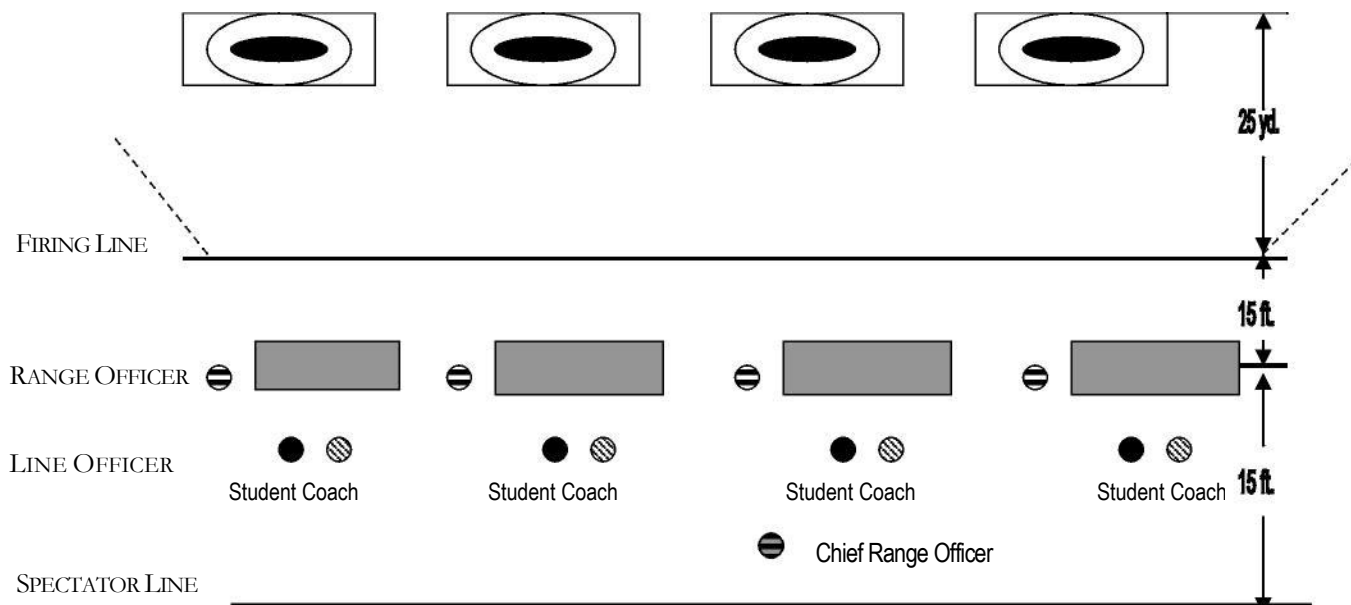

### PHASE II – Loading Exercise

Chief Range Officer commands “Relay (number) has begun. You may commence the training exercise. You have (number) minutes.”

1. Learner/Coach check firearm and equipment (see list). Hold hand up if in need of assistance, equipment, etc.
2. Range Officer command “Are the Loading Stations Ready?”  
     “Eye and ear protection on?”  
     “Check and clean firearm.”
3. Learner will check to insure firearm is unloaded, clean bore and go to firing line to snap caps to clear the flash channel (keep muzzle pointed in a safe direction), or inspect flintlock touchhole. Return to loading station and set firearm in loading position. The Coach will observe, instruct or assist (when necessary). Record learners performance on the Learner Performance Rating Sheet.
4. Range Officer command “Ready To Load?” Raise hand if not ready.  
     “Commence Loading!”
5. Learner loads while Coach observes, instructs, or assists and fills out the Learner Performance Rating Sheet.  
     At this point the firearm is loaded – “HOT.”  
     Firearms loaded at a loading bench remains at the loading bench. The learner steps back to indicate loading is completed.

Where a loading bench is not available and where everyone loads on command and fires on command, loading from the pouch at the Firing Line is acceptable. It is not acceptable if someone is shooting next to someone loading; a spark could ignite the powder of the nearby open powder horn. Point the firearm down range when loading at the Firing Line.

Muzzleloading Fact Sheet 43

# Shotgun Chokes and Patterns For Lead Shot

|            |                               |
|------------|-------------------------------|
| Full Choke | effective range<br>40 + yards |
|            | terminal range<br>200 + yards |

---

|                |                               |
|----------------|-------------------------------|
| Modified Choke | effective range<br>35 yards   |
|                | terminal range<br>200 + yards |

---

|                |                               |
|----------------|-------------------------------|
| Improved Choke | effective range<br>25 yards   |
|                | terminal range<br>200 + yards |

---

|            |                |
|------------|----------------|
| Full Choke | Improved Choke |
|------------|----------------|

---

|                |                |
|----------------|----------------|
| Modified Choke | Cylinder Choke |
|----------------|----------------|

## RANGE LAYOUT MUZZLELOADING LIVE FIRE PRACTICAL

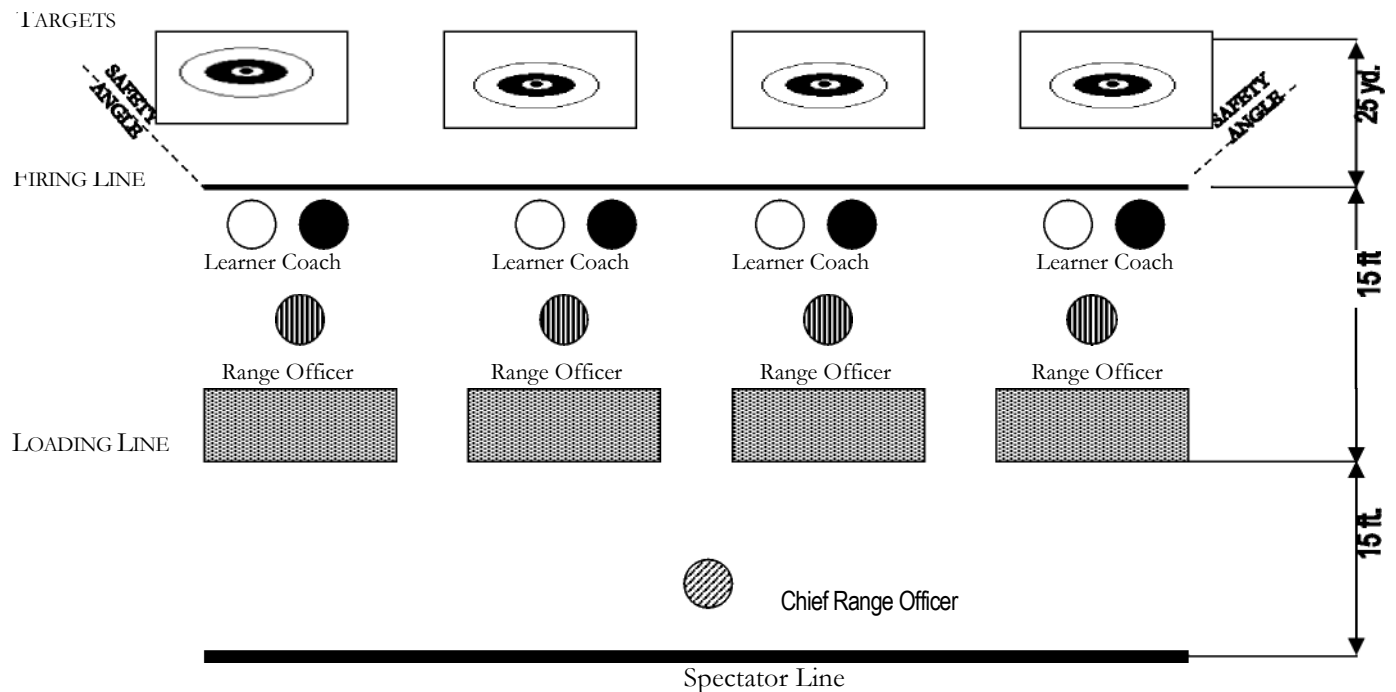

### PHASE III – Firing Exercise

1. Range Officer command “Proceed To Firing Line.”  
Learner picks up firearm, keep barrel vertical and muzzle above head.
2. Range Officer command, “Is the line ready?” Hold up hand if not ready.  
”You may Fire when Ready!”
3. Learner assumes a good body position and checks sight alignment. Without changing the body position, cap or prime. Preparing to fire the shot, reaffirm good body position, breath control, align sights, squeeze trigger, follow through and check target for shot placement. Shotgun clay bird hits have no recourse. It is a hit or miss. For misfires, re-prime or re-cap to fire again, or remove load with CO<sub>2</sub>. See text reference: Unit 7: if It Fails To Fire.
4. Learner/Coach, return only unloaded firearms to loading station. Clean bore with a moist patch followed by a dry patch to make ready to load again.
5. Repeat PHASE II and PHASE III through Step 5 until CRO announces “5 minutes remaining.”
6. Learners are to Field Clean the firearm at the 5 minute command.
7. Chief Range Officer commands “Cease Firing! Are there any hot ones?” No response, then “Bench all firearms.” CRO looks over the line to see that no one is handling a firearm. Then he announces “The line is Clear. Go forward to pull targets and/or post targets.” (Learners will bring their target to the next class.)

The roles will then “Rotate!” Learner to Coach, Coach to Range Office, Range Officer to Learner, and then on to the next discipline while a new learner joins the group. Persons performing as Chief Range Officer, Bird Puller and thrower will be decided on site.

Note: Learner “Range Officers” should be provided a “blaze orange” vest, cap, or armband to denote their position during the exercise.

At the end of the day, firearm cleaning teams will present their cleaned firearm to Course Instructors for inspection and Performance Rating.

Number of shots to be fired in a relay will be determined by:

- total range time available,
- number of firearms,
- number of firing points,
- range and weather conditions,
- number of and skill level of learners.

# Muzzle Loading

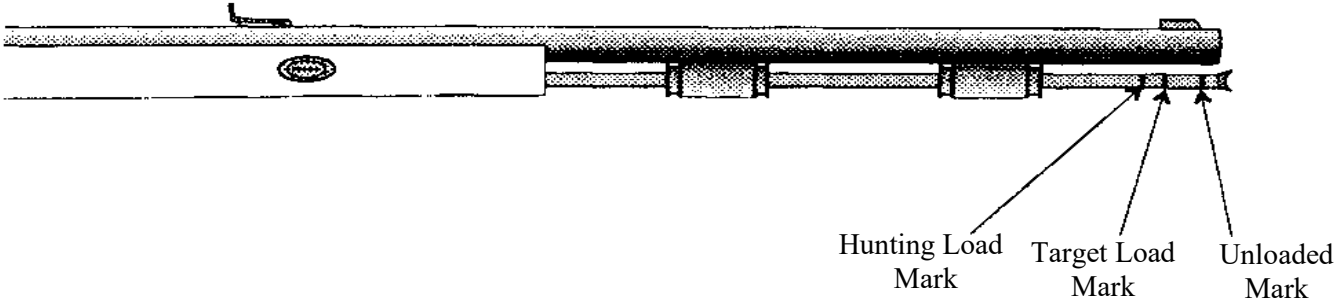
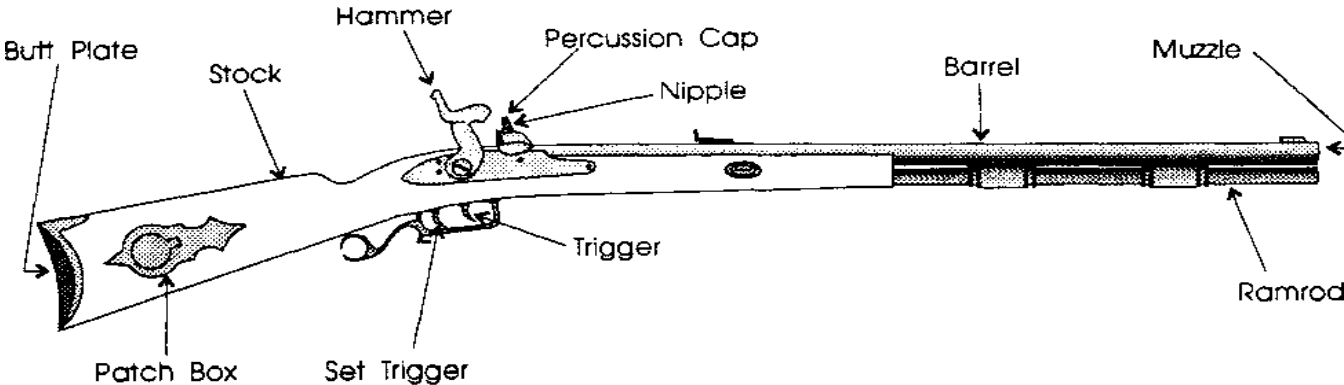

# ACCURACY & ANATOMICAL KNOWLEDGE ARE REQUIRED

*NEVER ATTEMPT ANY SHOT THAT IS BEYOND YOUR PRACTICED AND ACQUIRED SKILL.*

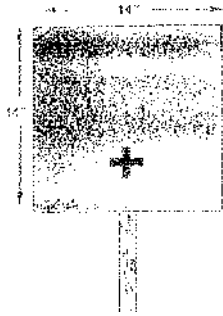

Fig. 1

Our suggested target size (see Chart C) approximates the chest area and shoulder height of a deer. Using this target size at various distances will help you to control the placement of each shot and to estimate range

Fig. 2

A living deer is not a one-dimensional flat surface as pictured on the standard "archery type" target. Think of the chest area of a deer as a box containing the vital organs of the animal. As the deer browses and moves about, this box is constantly moving, altering the optimum point of aim.

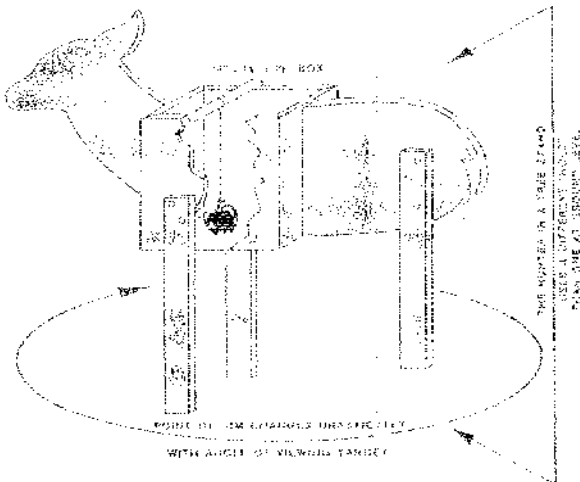
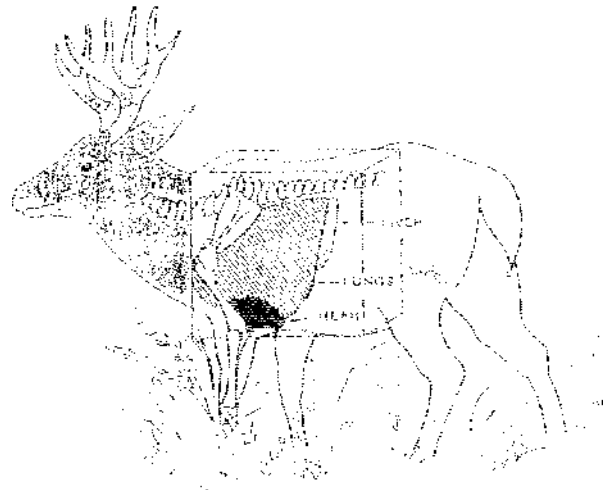

Fig. 3

While not to scale, this drawing illustrates a point. The deer hunter is attempting to hit a large apple (which he cannot see) hanging inside of a box. As he moves around the box, or climbs above it, his optimum point of aim changes drastically. Accuracy and a working knowledge of the deer's anatomy are essential.

## CHART D



**THOMPSON CENTER ARMS**  
ROCHESTER, NEW HAMPSHIRE 03867

### **Alternate Muzzleloading Loading Procedure**

This is an alternative loading procedure to running a damp patch down the barrel after each shot.

1. After firing the shot, return the muzzleloader to the loading table.
2. Drop a bare ramrod down the barrel and count to 3.
3. Repeat step 2 a minimum of four (4) times.
4. Continue with normal loading procedure (powder, patch, ball).

### **Reasoning**

The method of running a damp patch down the barrel, to extinguish any possible embers after every shot is still a viable loading procedure. It has been found, that some youth and instructors do not understand what a damp patch is, and end up running a wet patch down the barrel.

This pushes all the fouling, left in the barrel to the bottom of the breach. After a while, a buildup of wet fouling is at the bottom of the breach and won't allow the spark from the flash hole to reach the dry powder, causing a miss or hang fire.

An ember needs 3 things to burn, heat, oxygen, and a fuel source. By dropping the bare ramrod down the barrel, you are pushing oxygen to any remaining embers causing them to consume the fuel source and burn themselves out.

By following this loading procedure, and only running the damp patch down the barrel with the ball, all of the barrel fouling will be at the top of the dry powder and shot out the muzzle on the next shot.

## Muzzleloading Misfire Procedure

1. Keep the muzzleloader pointed in a safe direction down range for 60 seconds to ensure that there is not a “hang fire”.
2. At the end of the 60 seconds, a misfire may be declared.
3. After a misfire is declared, a nipple pick should be used to clean the nipple, a certified muzzleloading leader will reseal the ball with the muzzleloader pointed down range, place a cap on the nipple, and the youth may attempt another shot down range.
4. If the muzzleloader still fails to fire, keep the muzzleloader pointed in a safe direction down range for 60 seconds to ensure that there is not a hang fire. At this point you can continue to step 5 or go straight to step 7.
5. Remove the nipple, a certified muzzleloading leader will reseal the ball with the muzzleloader pointed down range, using a pick, remove some of the old powder and place a tiny amount of fresh powder in the breech, replace the nipple and attempt another shot down range.
6. If the muzzleloader fails to fire, keep the muzzleloader pointed in a safe direction downrange for 60 seconds to ensure that there is not a hang fire.
7. A 4-H certified adult muzzleloading leader will use a CO2 discharger for a minimum of 2 bursts to discharge the patch and ball. Make sure to reseal the ball between bursts.
8. If the ball has not been discharged after the steps above have been tried, only then can a ball be pulled.

### **Pulling a ball correctly for muzzleloading**

***A 4-H certified adult muzzleloading leader is the only person who can pull a ball during any 4-H practice or event.***

1. Create a safe area with a strap hanging from above within 3 to 4 feet of the firing line down range or on a secure point that will allow for the muzzle to be pointed downrange. This area shall be set up and identified prior to a practice or event.
2. Prior to pulling the ball, pour 5cc (1-teaspoon) of non-flammable liquid down the barrel and let soak for 5-minutes.
3. After the 5-minute time limit, remove the nipple and slowly squirt 2-3cc (1/2-teaspoon) of non-flammable liquid into the flash hole. Leave the nipple out.
4. Insert the range rod with the ball puller attached into the barrel and dig into the ball until the ball puller has a good grip.
5. Using the strap around the end of the range rod and allowing the muzzleloader to hang vertically with room for pulling downwards. If using a secure point downrange. Close the range from other participants and then proceed to wrap the strap around the range rod and pull horizontally backwards.
6. If the ball will not pull out, the breach end of the barrel must be soaked for at least an hour before removing the muzzleloader from the range.
7. A 4-H certified adult muzzleloading leader will deem it safe before the removal of the muzzleloader from the range. It is recommended the muzzleloader be taken to a gunsmith to remove the ball and make the gun safe.

## Level 1 Muzzleloading Training Outline

(Life Skills, PYD, need to be incorporated in the lessons.)

### Welcome

- Introduction
- Instructor Credentials
- Get to know each other activity (STEM, icebreaker, etc.)
- Schedule for the day

### First Shot Fundamentals

- See page 1 of discipline manual.

### Lessons (in no specific order)

- Equipment
  - Parts of Muzzleloader
  - Powder
  - Accessories
  - Tools
  - History
  - Actions
  - Loading Tables & Stands
- Loading procedure
- Cleaning
- Overview of Manual (specific for your state)
- Range layout
- Targets
- Competition / Scoring
- Range Safety
- Risk Management
- State Specific Rules and Events
- Coaching Skills
  - Oreo
  - Coaching Positions
  - Non-Threatening Hands-On Instruction
  - How to deal with problem students / parents
- Muzzleloader Malfunctions
  - Clearing
    - 4-F behind the nipple
    - CO2
    - Soaking
    - Pulling
  - Other
- Practicum Prep and Practicum
  - Debrief
- Closing / Wrap Up / Clean equipment

## **2026 Changes to Section 2 Muzzleloader Manual**

1. January – Added Curriculum Authorization statement to manual.
2. January – Renumbered pages and fixed index.
3. January – Added “Loading a Cap and Ball Revolver” to the end of Lesson 5.
4. January – Added “Alternate Muzzleloading Procedures” to end of document.
5. January – Added “Muzzleloading Misfire” and “Ball Pulling Procedure” to end of document.
6. January – Added a possible level 1 muzzleloading training outline to end of document.